

**Installation and Operation Guide  
for  
High Intensity Obstruction  
Lighting System**

**Model SG-60E**

**Manual Number EPM-00001152**

**Honeywell Airport Systems  
550 State Route 55  
Urbana, OH 43078  
Phone (937) 484-2000  
Fax (937) 484-2101  
[www.oblighting.com](http://www.oblighting.com)**

**HISTORY OF REVISIONS**

<b>Rev.</b>	<b>Comment</b>	<b>ECO#</b>	<b>Approved</b>	<b>Date</b>
A	First Release	4350	JAJ	12/22/04
B	Revise Parts List to reflect correct p/ns	4370	JAJ	6/28/05
C	Revise Input Power Fuses	4373	JAJ	8/9/05

**NOTICE**

The integrity and reliability of Honeywell airport lighting systems are dependent on the use of Honeywell parts and components. To ensure the optimum performance and reliability of your Honeywell system, it is strongly advised that only components and modules provided by Honeywell be used.

The following is Honeywell's standard Limited Warranty for Airport Systems Products ("Products"). This warranty applies unless a different warranty has been specifically agreed to and signed by Honeywell's authorized representative.

**1.1 LIMITED WARRANTY**

(a) "Nonconformance" means a defect in workmanship or material; a failure to comply with applicable Honeywell drawings; or a failure to comply with applicable FAA specifications. Normal wear and tear (including but not limited to incandescent lamp failure) or the need for periodic maintenance shall not constitute a Nonconformance.

(b) Honeywell warrants that at time of delivery to Buyer, its Products will comply with applicable Honeywell drawings and FAA specifications and will be free from defects in workmanship and material. These warranties shall run to Buyer, its successors and assigns. The duration of these warranties shall be as follows:

- (1) for non-LED-based obstruction lights, twenty-four (24) months after shipment of the Product;
- (2) for non-LED-based airfield lights and for Control and Monitoring Systems (excluding software and third-party components), twenty-four (24) months after shipment of the Product or twelve (12) months after date of first use, whichever occurs first;
- (3) for LED-based airfield and obstruction lights, five (5) years after shipment of the Product;
- (4) for Control and Monitoring System software developed by Honeywell, ninety (90) days from date of first use; and
- (5) for third party hardware and software components of Control and Monitoring Systems, in accordance with the warranty from the third party.

(c) Buyer must notify Honeywell in writing of a Nonconformance within the warranty period and return the Product to Honeywell within thirty (30) calendar days after such notice, in accordance with instructions which shall be issued by Honeywell. Honeywell's obligation and Buyer's remedy under this warranty is limited to either repair or replacement, at Honeywell's option, of the nonconforming Product. All Products repaired or replaced hereunder shall be warranted only for the unexpired portion of the original warranty period. Honeywell agrees to assume round trip transportation costs for a nonconforming Product in an amount not to exceed normal ground shipping charges to the warranty service facility designated by Honeywell. The risk of loss or damage to all Products in transit shall be borne by the Party initiating the transportation of such Products.

(d) Honeywell shall not be liable under this warranty if the Product has been exposed or subjected to (1) any maintenance, repair, installation, handling, transportation, storage, operation or use which is improper or otherwise is not in compliance with Honeywell's instructions; or (2) any alteration, modification or repair by anyone other than Honeywell or those specifically authorized in writing by Honeywell; or (3) any accident, contamination, foreign object damage, abuse, neglect or negligence after delivery to Buyer; or (4) any damage precipitated by failure of a Honeywell supplied Product not under warranty or by any product not supplied by Honeywell.

(e) THIS WARRANTY IS EXCLUSIVE AND IN LIEU OF ALL OTHER WARRANTIES, WHETHER WRITTEN OR ORAL, EXPRESS, IMPLIED OR STATUTORY, INCLUDING, WITHOUT LIMITATION, ANY IMPLIED WARRANTIES OF MERCHANTABILITY, FITNESS FOR PARTICULAR PURPOSE, OR NON-INFRINGEMENT, ALL OF WHICH ARE HEREBY EXPRESSLY DISCLAIMED. NO EXTENSION OR EXPANSION OF THIS WARRANTY SHALL BE BINDING UPON HONEYWELL UNLESS SET FORTH IN WRITING AND SIGNED BY HONEYWELL'S AUTHORIZED REPRESENTATIVE.

(f) IN NO EVENT SHALL HONEYWELL BE LIABLE FOR SPECIAL, INDIRECT, INCIDENTAL OR CONSEQUENTIAL DAMAGES UNDER THIS WARRANTY EVEN IF ADVISED OF THE POSSIBILITY OF SUCH DAMAGES INCLUDING, WITHOUT LIMITATION, INTERRUPTION OF BUSINESS, LOSS OF PROFITS, OR LOSS OF USE. THE EXCLUSION OF INCIDENTAL AND CONSEQUENTIAL DAMAGES AS SET FORTH IN THIS WARRANTY SHALL BE DEEMED INDEPENDENT OF, AND SHALL SURVIVE, ANY FAILURE OF THE ESSENTIAL PURPOSE OF ANY LIMITED REMEDY UNDER THE TERMS OF THIS WARRANTY

**DISCLAIMERS**

This manual could contain technical inaccuracies or typographical errors. Honeywell reserves the right to revise this manual from time to time of the contents thereof without obligation of Honeywell to notify any person of such revision or change. Details and values given in this manual are average values and have been compiled with care. They are not binding, however, and Honeywell disclaims any liability for damages or detriments suffered as a result of reliance on the information given herein or the use of product, processes or equipment to which this manual refers. No warranty is made that the use of the information or of the products processes or equipment to which this manual refers will not infringe any third party's patents or rights. The information given does not release the buyers from making their own experiments and tests.

**TABLE OF CONTENTS**

1.1 LIMITED WARRANTY..... I

**SAFETY INFORMATION..... V**

**SECTION 2. GENERAL INFORMATION..... 2-1**

2.1 SCOPE.....2-1

2.2 GENERAL DESCRIPTION.....2-1

2.2.1 Model SGC-60 Master Controller.....2-1

2.2.2 Model SGF-60 Flashhead.....2-1

2.2.3 Ambient Light Sensor (P/N 12H00107-001).....2-11

2.3 SAFETY PRECAUTIONS.....2-3

2.4 SPECIFICATIONS.....2-77

**SECTION 3. INSTALLATION & POWER UP ..... 3-1**

3.1 UNPACKING.....3-1

3.2 SYSTEM CONFIGURATION.....3-1

3.2.1 Master Controller Configuration.....3-1

3.2.2 Flashhead Configuration.....3-3

3.3 INSTALLATION.....3-6

3.3.1 SGC-60 Master Controller.....3-6

3.3.2 SGF-60 Flashhead.....3-6

3.3.3 Ambient Light Sensor (Photocell).....3-7

3.3.4 Cables and Junction Boxes.....3-7

3.4 INSTALLATION WIRING.....3-10

3.4.1 Master Controller to Photocell Wiring.....3-11

3.4.2 Master Controller Data/Communications Wiring.....3-11

3.4.3 Master Controller Power Wiring.....3-11

3.4.4 Master Controller Wiring For Dual Systems.....3-12

3.4.5 Flashhead Wiring.....3-13

3.4.6 Conduit and Tower Wiring Detail.....3-13

3.4.7 Junction Box Details.....3-16

3.5 FINAL INSTALLATION CHECK.....3-24

3.5.1 Preliminary.....3-24

3.5.2 Verify Correct Wiring in Master Controller.....3-24

3.5.3 Verifying Photocell Wiring.....3-24

3.5.4 Verify Proper Tower Wiring for Data/Control Cable.....3-24

3.6 POWER UP AND SYSTEM TESTS.....3-25

3.6.1 Master Controller Status Indicators.....3-25

3.6.2 Flashhead Status Indicators.....3-26

3.6.3 System Power Up.....3-26

3.6.4 Verify Local Mode Operation.....3-27

3.6.5 Verify Photocell Operation Connected to Controller.....3-29

3.6.6 Verify Photocell Operation Not Connected to Controller.....3-30

**SECTION 4. PRINCIPLES OF OPERATION..... 4-1**

4.1 OVERALL DESCRIPTION.....4-1

4.2 SGF-60 FLASHHEAD.....4-1

4.2.1 SGF-60 Motherboard.....4-3

4.2.2 SGF-60 Digital Board.....4-3

4.2.3 SGF-60 Trigger/High-Voltage Board.....4-6

4.3 SGC-60 MASTER CONTROLLER.....4-7

4.3.1 Power Supply.....4-7

4.3.2 Flash Requests and Flashhead Status.....4-8

4.3.3 System Mode Selection.....4-8  
 4.3.4 Communications Circuitry .....4-9

**SECTION 5. TROUBLESHOOTING ..... 5-1**

**SECTION 6. MAINTENANCE ..... 6-1**

6.1 SGC-60 MASTER CONTROLLER.....6-1  
 Transformer Replacement.....6-1

6.2 SGF-60 FLASHHEAD .....6-2  
 6.2.1 Flash tube Replacement .....6-2

6.3 AMBIENT LIGHT SENSOR (PHOTOCELL) .....6-3

**SECTION 7. REPLACEMENT PARTS ..... 7-1**

**SECTION 8. ANTENNA OBSTRUCTION LIGHT (AOL) ..... 8-1**

**TABLE OF FIGURES**

Figure 2-1: Model SGC-60 Master Controller ..... 2-22

Figure 2-2: Model SGF-60 Flashhead ..... 2-33

Figure 3-1: Flash tube Installation ..... 3-5

Figure 3-2: Master Controller Mounting Dimensions ..... 3-8

Figure 3-3: Flashhead Outline and Mounting Dimensions ..... 3-9

Figure 3-4: Typical Wiring Installation..... 3-10

Figure 3-5: Flex Conduit Typical Installation Layout..... 3-14

Figure 3-6: Junction Box Wiring Details ..... 3-16

Figure 3-7: Flex Conduit Installation Detail..... 3-18

Figure 3-8: WC000001 Cable Overview..... 3-199

Figure 3-9: Flashhead Cable ..... 3-21

Figure 3-10: Master Controller Circuit Board ..... 3-22

Figure 3-11: Flashhead Digital Control Board ..... 3-23

Figure 4-1: Master Controller Board Schematic ..... 4-10

Figure 4-2: SGF-60E Flashhead System Schematic..... 4-11

Figure 4-3: SGF-60E Digital Board Schematic..... 4-12

Figure 4-4: SGF-60E Trigger/High-Voltage Board Schematic..... 4-13

Figure 5-1: General Troubleshooting – All Flashheads Stuck in Day Mode ..... 5-3

Figure 5-2: General Troubleshooting – Flashhead Does Not Flash ..... 5-4

Figure 5-3: General Troubleshooting – Flashhead Stuck in Day Mode ..... 5-5

Figure 5-4: Dual System-Specific Troubleshooting ..... 5-6

Figure 5-5: Catenary System-Specific Troubleshooting Chart ..... 5-7

Figure 6-1: SGC-60 Replacement Transformer ..... 6-1

Figure 6-2: Flash tube Installation ..... 6-3

Figure 8-1: SG-60 AOL Flashhead Mounting Dimensions ..... 8-2

Figure 8-2: SG-60 AOL Power Supply Mounting Dimensions ..... 8-3

Figure 8-3: SG-60 AOL Wiring Installation ..... 8-4

Figure 8-4: SG-60 AOL Flashhead Component Locations ..... 8-5

Figure 8-5: SG-60 AOL Power Supply Component Locations..... 8-6

Figure 8-6: SG-60 AOL Schematic..... 8-7

## SAFETY INFORMATION

This section contains general safety instructions for using your Honeywell equipment. Task and equipment-specific Warnings are included in other sections of this manual where appropriate. Read all Warnings and follow all instructions carefully. Failure to do so may result in personal injury, death, or property damage. To use this equipment safely, refer to the following:

1. Refer to the FAA Advisory Circular *AC 150/5340-26, Maintenance of Airport Visual Aids Facilities*, for instructions on safety precautions.
2. Observe all safety regulations. To avoid injuries, always remove power prior to making any wire connections and/or touching any parts. Refer to FAA Advisory Circular *AC 150/5340-26*.
3. Read and become familiar with the general safety instructions provided in this section of the manual before installing, operating, maintaining, or repairing this equipment.
4. Read and carefully follow the instructions given throughout this manual before performing specific tasks and working with specific equipment.
5. Store this manual within easy reach of personnel installing, operating, maintaining, or repairing this equipment.
6. Follow all applicable safety procedures required by your company, industry standards, and government or other regulatory agencies.
7. Obtain and read Material Safety Data Sheets (MSDS) for all materials used.

## SAFETY AND WORKMANSHIP ALERTS

This manual uses two types of markings when giving instructions requiring special attention. The markings will be followed by indented text:

**WARNING!**

The **WARNING** sign in this manual denotes a hazard. The **WARNING** calls attention to a procedure or practice which, if not correctly performed or adhered to, could result in property damage, injury or death. Do not proceed beyond a **WARNING** sign until the indicated conditions are fully understood and met.

**CAUTION**

Failure to obey the instructions following a **CAUTION** marking may result in equipment damage.

## QUALIFIED PERSONNEL

The term “qualified personnel” is defined here as individuals who thoroughly understand the equipment and its safe operation, maintenance, and repair. Qualified personnel are

physically capable of performing the required tasks, familiar with all relevant safety rules and regulations and have been trained to safely install, operate, maintain, and repair the equipment. It is the responsibility of the company operating this equipment to see that its personnel meet these requirements.

### INTERLOCKS

This equipment contains interlocks for your protection. To ensure safety, always remove power from the equipment prior to opening access panels or doors if possible. Do not depend on the interlocks or door switches when working with the equipment. Do not short-circuit or tamper with any access gate, door or other safety interlock switch. Discharge capacitors with an approved insulated grounding rod prior to touching any part. When it is absolutely mandatory that an interlock be bypassed for the purpose of tracing or correcting a malfunction, authorized maintenance personnel may perform the bypass for the specific test to be made. Immediately after completing the test, restore the interlock to working condition.

**WARNING!**

### INTENDED USE

**HONEYWELL IS NOT RESPONSIBLE FOR INJURIES OR DAMAGES RESULTING FROM NONSTANDARD, UNINTENDED APPLICATIONS OF ITS EQUIPMENT. THIS EQUIPMENT IS DESIGNED AND INTENDED ONLY FOR THE PURPOSE DESCRIBED IN THIS MANUAL. USES NOT DESCRIBED IN THIS MANUAL ARE CONSIDERED UNINTENDED USES AND MAY RESULT IN SERIOUS PERSONAL INJURY, DEATH OR PROPERTY DAMAGE. UNINTENDED USES MAY RESULT FROM TAKING ANY OF THE ACTIONS LISTED BELOW.**

1. Making changes to the equipment that have not been recommended or described in this manual, or using parts that are not genuine Honeywell replacement parts.
2. Failing to make sure that auxiliary equipment complies with approval agency requirements, local codes, and all applicable safety standards.
3. Using materials or auxiliary equipment that are inappropriate or incompatible with your Honeywell equipment.
4. Allowing unqualified personnel to perform any task.

**WARNING!**

**KEEP AWAY FROM LIVE CIRCUITS. OPERATION AND MAINTENANCE PERSONNEL MUST OBSERVE ALL SAFETY REGULATIONS AT ALL**

**TIMES. DO NOT CHANGE PLUG-IN COMPONENTS OR MAKE ADJUSTMENTS INSIDE EQUIPMENT WITH THE HIGH VOLTAGE SUPPLY ON. UNDER CERTAIN CONDITIONS, THERE IS A POTENTIAL FOR SERIOUS INJURY FROM CIRCUITS WITH POWER CONTROLS IN THE OFF POSITION. THIS IS DUE TO CHARGES RETAINED BY THE CAPACITORS. TO AVOID SERIOUS INJURY, ALWAYS DISCONNECT POWER, THEN DISCHARGE CAPACITORS BY USING AN APPROVED GROUNDING ROD PRIOR TO TOUCHING ANY PART.**

**RESUSCITATION. MAINTENANCE PERSONNEL SHOULD BE TRAINED IN CARDIOPULMONARY RESUSCITATION (CPR).**

**CAUTION**

**This equipment contains static sensitive semiconductor devices and integrated circuits that may be damaged by Electro-Static Discharge (ESD). Take the necessary precautions before attempting service.**

**Any replacement circuit boards should be kept in metallized anti-static bags until immediately before installation. Ground yourself (touch the outside of a grounded metal enclosure) before removing circuit boards from their protective bags. Avoid touching components when handling the boards.**



## SECTION 2. GENERAL INFORMATION

### 2.1 Scope

This manual provides information about the installation, operation, and maintenance of the StrobeGuard®, Model SG-60E, High Intensity Obstruction Lighting System manufactured by Honeywell.

### 2.2 General Description

The StrobeGuard® system is a high intensity flashing white obstruction lighting system with a Xenon flash tube as the light source. It designed for use as a high intensity aviation obstruction warning system. The system is designed and manufactured to comply with Federal Aviation Administration Advisory Circular 150/5345-43E. The StrobeGuard® system can support up to 24 Flashheads controlled by a single controller at distances up to 2500 feet. The Flashheads are FAA light type L-856 or L-857.

System components are shown in Figure 2-1 on Page 2-2, and on Page 2-3. The system consists of the following units:

- Model SGC-60 Master Controller
- Model SGF-60E Flashhead
- Ambient Light Sensor

#### 2.2.1 Model SGC-60 Master Controller

The Master Controller is a microprocessor-based system that controls the flash interval and timing, flash intensity, and monitors the complete StrobeGuard® system. The controller is designed with LED status indicators and relays for remote alarming.

#### 2.2.2 Model SGF-60E Flashhead

The Flashhead is designed as a capacitor discharge xenon flash tube unit. The Flashhead consists of the following major components:

- Xenon Flash tube and Reflector Assembly
- Trigger Circuit Board
- High Voltage Circuit Board
- Capacitor Assembly
- Ferro resonant Transformer Assembly
- Power Interlock Switch
- Mode Interlock Switch
- Logic Control Circuit Board
- Terminal Block, Fuse, Surge Suppressor Assembly

#### 2.2.3 Ambient Light Sensor (P/N 12H00107-001)

The Ambient Light Sensor (photocell) is used to provide input to the controller. With this input, the controller adjusts the operation of the system between day, twilight, and night.

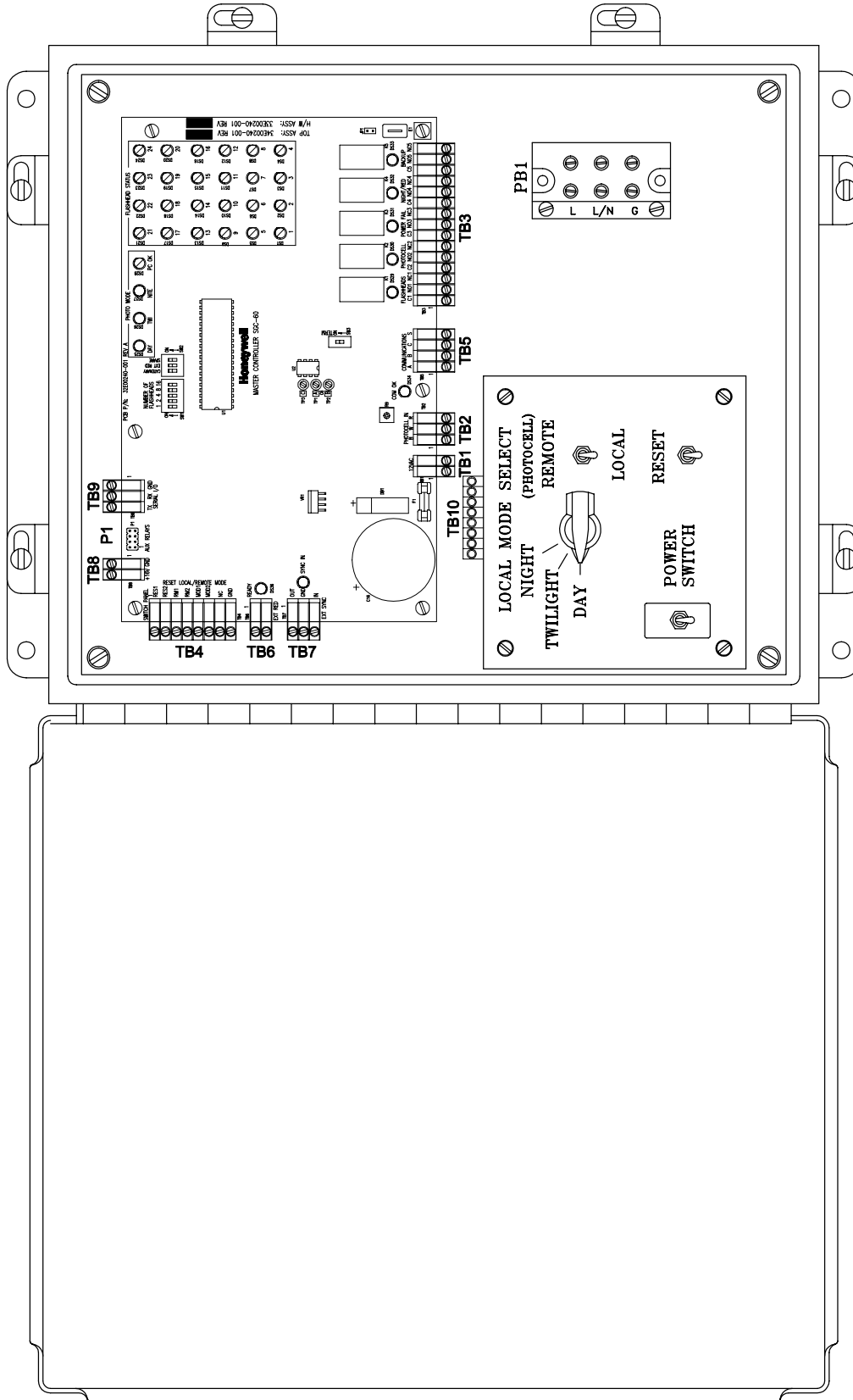

Figure 2-1: Model SGC-60 Master Controller

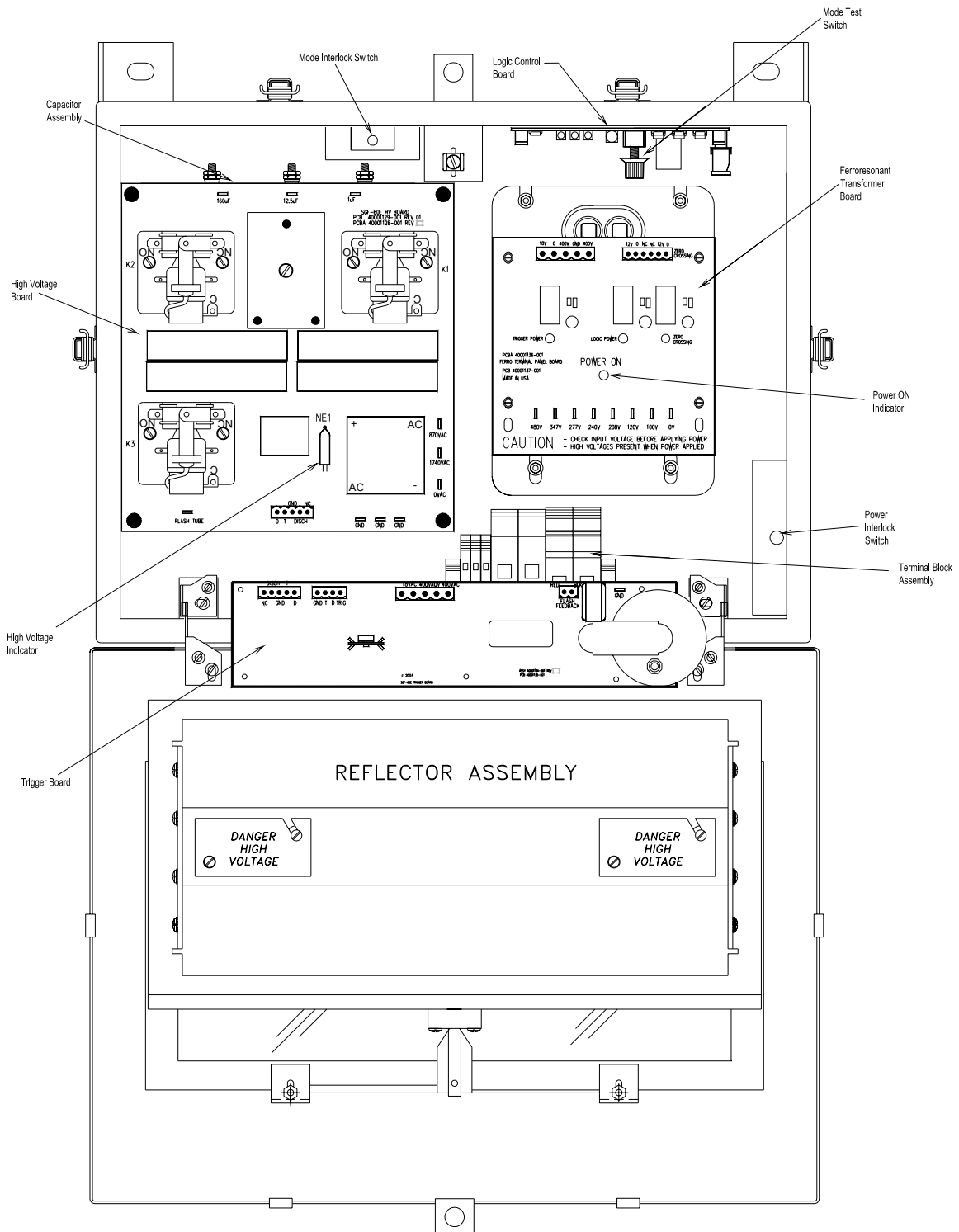

Figure 2-2: Model SGF-60E Flashhead

## 2.2 Safety Precautions

The following general safety precautions must be observed during all phases of operation, service, and repair of this equipment. Failure to comply with these precautions or with specific warnings elsewhere in this manual violates safety standards of design, manufacture, and intended use of this equipment. Honeywell assumes no liability for the customer's failure to comply with these requirements, as listed below.

1. Any interruption of the protective grounding conductor (inside or outside the instrument) or disconnecting the protective earth ground terminal is likely to make this equipment dangerous. Intentional interruption is prohibited.
2. Whenever it is likely that the ground protection has been impaired, the equipment must be made inoperative by removing AC line power, and then shall be secured against any unintended operation.
3. Ensure that only fuse / Breakers with the required rated current and of the specified type (normal blow, time delay, etc.) are used for replacement. The use of repaired fuses and the short-circuiting of fuse holders must be avoided.
4. Electrical energy available at many points may result in personal injury or death if touched. Any adjustment, maintenance, and repair of the opened equipment while power is applied shall be avoided as much as possible, however some maintenance described in this manual is performed with power supplied to the equipment while protective covers are removed. When repair with power applied is unavoidable, only a skilled person who is aware of the hazard involved shall carry out maintenance. Do not attempt internal service or adjustment unless another person, capable of rendering first aid and resuscitation, is present.
5. Do not install, substitute parts or perform any unauthorized modification to the equipment.
6. Make sure the input voltage selection on the Ferro resonant transformer assembly matches the line voltage before applying power to the unit.

**Capacitors inside the equipment may still be charged after the equipment has been disconnected from its power source, even though the equipment was designed to drain charge from the capacitors when power is removed. Do not put hands or tools in the Flashhead if the High Voltage Indicator neon lamp NE1 is ON, which is located on the High Voltage Circuit Board. (Refer to Figure 2-2, Page 2-3)**

7. Do not confuse the High Voltage Indicator NE1, with the POWER ON Indicator located on the Ferro resonant Transformer Assembly. It is possible for the High Voltage Indicator NE1 to be ON After the main AC power to the unit is turned OFF (POWER ON Indicator is OFF). If

this happens, the energy stored in the capacitor Assembly must be discharged before performing maintenance.

8. Capacitor Discharge Procedure. Attach one end of the capacitor discharge tool to chassis ground first, then the other end to any of the relay terminals. Hold for 3 seconds, or until the indicator turns off.

**WARNING!**

This system uses lethal voltages in the Flashhead. Unless absolutely necessary, do not attempt to service or adjust the equipment with AC line power applied.

Safety interlock switches are provided in the Flashhead enclosure to interrupt main AC power to the power supply. These interlock switches are activated when the Flashhead door is opened in a conventional manner. No interlock is provided when other means of access are used. Do not tamper with the interlocks by opening or shorting the terminals.

The POWER ON Indicator is ON when the Ferro resonant Transformer is powered. If the POWER ON Indicator is OFF, Line input AC power may still be present in the system.

**AC LINE VOLTAGE IS STILL PRESENT WHEN INTERLOCKS ARE ACTIVATED. DISCONNECT POWER AT THE MAIN AC CIRCUIT BREAKERS BEFORE INSPECTING OR SERVICING, UNLESS ABSOLUTELY NECESSARY TO PERFORM MAINTENANCE WITH POWER ON.**

**WARNING!**

Flash tubes in this lighting system produce brilliant flashes of light containing some ultraviolet radiation that can cause temporary or permanent eye damage.

**DO NOT LOOK DIRECTLY AT THE FLASHHEAD WHILE IT IS IN OPERATION.**

**2.4 Specifications**

Light Output:

Day Intensity .....	270,000 ±25% effective candelas, single flash
Twilight Intensity .....	20,000 ±25% effective candelas, single flash
Night Intensity .....	2,000 ±25% effective candelas, burst of flashes
Beam Pattern.....	120° horizontally, 3° min. vertically
	Max. Intensity of 3% of peak at -10°
Flash Rate: Day .....	40 fpm - single white flash
Twilight .....	40 fpm - single white flash
Night .....	40 fpm - white burst of flashes
Master/Slave Operation .....	Up to 24 SGF-60E Flashheads may share a common sync and photocell circuit from one SGC-60 Master Controller.

Electrical Input:

Master Controller .....	50 Watts. 120, 208, 240, 277, 380, 480 VAC. 50, 60Hz
Flashhead .....	500 Watts. 100, 120, 208, 240, 277, 347, 480 VAC. 50, 60Hz

Mechanical Properties:

Flashhead	
Weight .....	82 pounds (37.2 kg)
Dimensions .....	18.88"w (479.4mm) x 15.25"h (387.4mm) x 15.75"d (400.0mm)
Surface Area .....	1.89 square feet
Wind Load.....	100 pounds at 150 mph (240kph)

Master Controller	
Weight .....	24 pounds (10.89 kg)
Dimensions .....	14"w (356mm) x 12"h (305mm) x 6"d (152mm)

Operating Environment:

Operating Temperature .....	-55°C to +55°C
Humidity .....	95% relative humidity

System Operating Status Indicators:

Flashhead, AC line power present.....	POWER ON Indicator
Flashhead, high voltage present on capacitors .....	High Voltage Indicator NE1

Master Controller Indicators

Flashhead Status.....	LEDs DS1 - DS24, red/green
Day Mode .....	LED DS25 red
Twilight Mode.....	LED DS26 red
Night Mode .....	LED DS27 red
Flashhead Fail .....	Relay K1 de-energized and LED DS29 Off
Photocell Fail .....	Relay K2 de-energized and LED DS30 Off
Power Fail.....	Relay K3 de-energized and LED DS31 Off
Night Mode Operation .....	Relay K4 de-energized and LED DS32 Off
White Night Backup (Dual Systems).....	Relay K5 energized and LED DS33 On

**SECTION 3. INSTALLATION & POWER UP**



**Modifications to the Power Supply are required for certain applications. Remove input power at circuit breakers and discharge capacitors with an approved grounding rod before attempting any necessary modifications.**

**3.1 Unpacking**

Carefully unpack each item and remove any internal packing material from the master controller, and the Flashhead power supply. Carefully check the supplied materials with the High Intensity Lighting System bill of materials. There are many small items that should be supplied inside clear plastic bags, verify each of these bags contain the proper amount of parts per the bill of materials. Report any shortages of materials immediately to the Honeywell Technical Support.

Examine each item for obvious physical damage. Report any claims to the carrier immediately. Pertinent information such as installation drawings, schematics, interconnection drawings, and operation manuals are included in the Master Controller carton. The flash tubes are packaged separately inside each Flashhead carton. Do not remove flash tubes from their boxes until you are ready to install them.

**3.2 System Configuration**

Honeywell pre-configures the system to match the installation. However, there are cases where complete installation information is not available prior to the system leaving the factory or the installation has changed. Setting the configuration may also be necessary when replacing individual units in the system. The following is a guide for configuring the Master Controller and the Flashheads.

**3.2.1 Master Controller Configuration**

There are a number of system control switches and configuration switch blocks (DIP switches) on the Master Controller. The configuration switch blocks may have multiple switches. Reference to the individual switches will be made by referring to the switch block number followed by the number of the individual switch as labeled on the switch block. For example, SW1 (Figure 3-, Item 1, Page 3-22) has 5 individual switches. The third switch from the left is labeled as #3 on the switch block and will be referred to as SW1-3.

**3.2.1.1 *System Controls***

Set Master Controller switches (Figure 2-1, Page 2-2) as follows:

POWER SWITCH ----- OFF  
 LOCAL / REMOTE Switch ----- LOCAL  
 MODE Switch ----- DAY



The Master Controller has the following control switches (Figure 2-1, Page 2-2):

- **POWER SWITCH:** Toggle switch that turns input AC line power on/off in the Master Controller. Does not affect AC power to the Flashheads. Input voltage is present at terminal block PB1, even with the power switch turned off.
- **RESET Switch:** Momentary pushbutton that resets the Master Controller. Switch must be held for about one second to activate.
- **REMOTE / LOCAL Mode Switch:** Two-position toggle switch that permits manual (local) selection of the flash intensity level using the DAY / TWILIGHT / NIGHT rotary switch. In normal (remote) operation, permits automatic operation controlled by the Ambient Light Sensor photocell.
- **DAY / TWILIGHT / NIGHT Switch:** Three-position rotary switch that allows manual selection of three light intensities of the system (DAY = high, TWILIGHT = intermediate, and NIGHT = low). The REMOTE / LOCAL Mode Switch must be in the LOCAL position to use this switch.

### 3.2.1.2 Power Configuration

The input voltage selection is set at the factory prior to shipping. The user shall verify the correct voltage as indicated by the label by Power In terminal block PB1 (Figure 2-1, Page 2-2). If the voltage listed on the label does not match the voltage at the site, contact Tech Support at (805) 581-5591.

### 3.2.1.3 Configuration Switches

- SW1 – (Figure 3-, Item 1, Page 3-22). This switch is used to set the number of Flashheads (including antenna obstruction light (AOL)) in the system up to 24. If the switches are set for more than 24 the system will still monitor only 24 Flashheads. The number of lights configured equals the sum of all the switches set to ON (positive binary). For example, to configure for 10 Flashheads, set SW1-4 (8 lights) to ON and SW1-2 (2 lights) to ON for a total of 10 (8+2) lights.
  - SW1-1 – Set to ON (up) for 1 light
  - SW1-2 – Set to ON (up) for 2 lights
  - SW1-3 – Set to ON (up) for 4 lights
  - SW1-4 – Set to ON (up) for 8 lights
  - SW1-5 – Set to ON (up) for 16 lights
- SW2 – (Figure 3-, Item 2, Page 3-22) This switch is used to set for Catenary operation (suspended cable warning lights) and for Dual systems (Red lights at night, and white strobes during the day).
  - SW2-1 – Set to ON (up) for Catenary system.
  - SW2-2 – Set to ON (up) for Dual system.
  - SW2-3 – Set to OFF (down). Reserved for future use.

- SW3 – (Figure 3-, Item 8, Page 3-22) This switch is used to set the termination resistor for the communications line.
  - SW3-1 – Set to ON if the Master Controller is at the end of the communications line. In a typical installation, the communications lines are terminated at the Master Controller and at the top level of Flashheads. In this case, this switch should be set ON.

### 3.2.2 Flashhead Configuration

The entire configuration for the Flashhead is done on the Logic Control Circuit Board. Because of the high voltage present in the Flashhead, there are interlock switches and fuses as follows (Figure 2-2, Page 2-3):

- POWER Interlock Switch: Three-position push/pull Double Pole switch. When the Flashhead door is opened, the switch interrupts AC line power to the Ferro resonant transformer and de-energizes a relay on the High Voltage Board which discharges the energy stored in the Capacitor Assembly. To defeat the interlock action, pull out the switch plunger, and power will be applied to the system with the door open.
- MODE Interlock Switch: Three-position push/pull single pole switch. When the Flashhead door is opened, it transfers flash intensity mode select from the remote SGC-60 Master Controller to local control, using the Logic Board rotary Mode Test Switch. To defeat the interlock action, pull out the switch plunger and the Flashhead will operate under remote mode SGC-60 control.
- MODE TEST Switch: Three-position rotary switch allows local flash intensity mode selection (Day, Twilight or Night) for the individual Flashhead when the door is open, while not affecting the operation of any other Flashhead in the system.
- Main Power Line Fuse: Provides protection for AC power to Ferro resonant transformer. Honeywell provides the correct fuse for the supplied power configuration.
- Housekeeping Power Thermal Breakers: Located on the Ferro resonant Transformer Board, it provides protection for the AC power to the logic and trigger board.

#### 3.2.2.1 *Power Configuration*

The Flashhead(s) are factory set for the correct AC input line voltage. However, the user shall verify that the input voltage selector, in the Ferro resonant Transformer Assembly, is set to the line voltage. If the voltage is not set properly, the main power line fuses may blow and the Ferro resonant transformer could be damaged.

### 3.2.2.2 Configuration Switches (Figure 3-7, Page 3-23)

- SW1 – This switch is used to reset the processor
  - Press and hold – resets the processor and tests the automatic power reset circuit. Press and hold SW1 until the LED DS1 (5V power indicator) turns OFF momentarily, then release.
- SW2 – This switch is used to set special operation options. Set all four switches to OFF unless your system meets one of the two conditions below:
 

*CONDITION 1: You have a Catenary System*

  - SW2-1 – Set ON for all Flashheads on top level of a Catenary installation.
  - SW2-2 – Set ON for all Flashheads on bottom level of Catenary installation.
  - SW2 -1 & -2 – Set both to ON for all Flashheads on middle level of a Catenary installation.

*CONDITION 2: You have Dual (Red/White) system with an older-model Master Controller.*

  - SW2-3 – Set to ON. **This is provided for backward compatibility with older installations only. For new installations this switch is always OFF. For older white-only installations this switch is also OFF.** To determine if an existing installation has an older Master Controller, refer to the new Master Controller in Figure 3-, Page 3-22. Older Master Controllers do not have terminals TB5-TB9, or an EXT RED switch SW2-2 (Item 2 in the figure).
  - SW2-4 is a spare Switch reserved for future use.
- SW3 – Used to specify the ID number for the Flashhead. Each Flashhead must be set with a unique ID number as indicated on the installation drawings. There is a diagram next to the switch showing the values for the switch. The ID number is the total of the values of the switches set to OFF (negative binary). For example, to set ID #10, set SW3-2 (value 2) OFF (down) and SW3-4 (value 8) OFF (down) for a total of 10 (2+8).
  - SW3-1 – Set to OFF (down) for value 1
  - SW3-2 – Set to OFF (down) for value 2
  - SW3-3 – Set to OFF (down) for value 4
  - SW3-4 – Set to OFF (down) for value 8
  - SW3-5 – Set to OFF (down) for value 16
- SW4 – This is used for the terminating resistor on the communications line.
  - SW4-1 – Set to ON (up) for terminating resistor. This should be set ON only for the Flashhead where the communication lines are terminated. In a typical installation, the communications lines are terminated at the Master Controller and the upper most Flashhead. In systems with an AOL, the AOL is typically the upper most Flashhead. In systems without an AOL, **any one, and only one** of the Flashheads at the top level can be set to ON. For all others, set to OFF. If the system is being installed in stages as the tower is erected, SW4-1 should be set ON for one of the Flashheads at the highest installed level. As additional Flashheads are

added at higher levels, adjust the configuration by setting SW4-1 to OFF in the previous Flashhead and set SW4-1 to ON for one of the Flashheads at the highest installed level.

### 3.2.2.3 Flash tube Installation

To prevent damage during shipping, the Flashheads are shipped from the factory with the flash tubes packaged separately. Install the flash tubes per the following procedure:

1. If Flashhead is already wired to AC power: Shut off the power to the system by opening the main AC power circuit breakers and unplugging the unit.
2. Release the Flashhead cover latches.
3. Swing the cover open, exercising caution not to damage the glass face or the gasket.
4. Unpack the flash tube. **Do not** touch the glass envelope - contamination from a fingerprint will degrade the reliability of the flash tube. If you accidentally touch the quartz tube, wipe it carefully with an alcohol swab.
5. Holding the flash tube by its metal ends, center it in the reflector assembly and snap it into place. Make sure the red mark on the flash tube matches the red mark on the socket assembly.
6. Attach the fast-on connector at each end of the flash tube to each socket assembly. Make sure wires are not twisted - the metal to glass bond is fragile.
7. Dress the electrode wires away from the sides of the reflector.
8. Close and fasten the Flashhead cover.

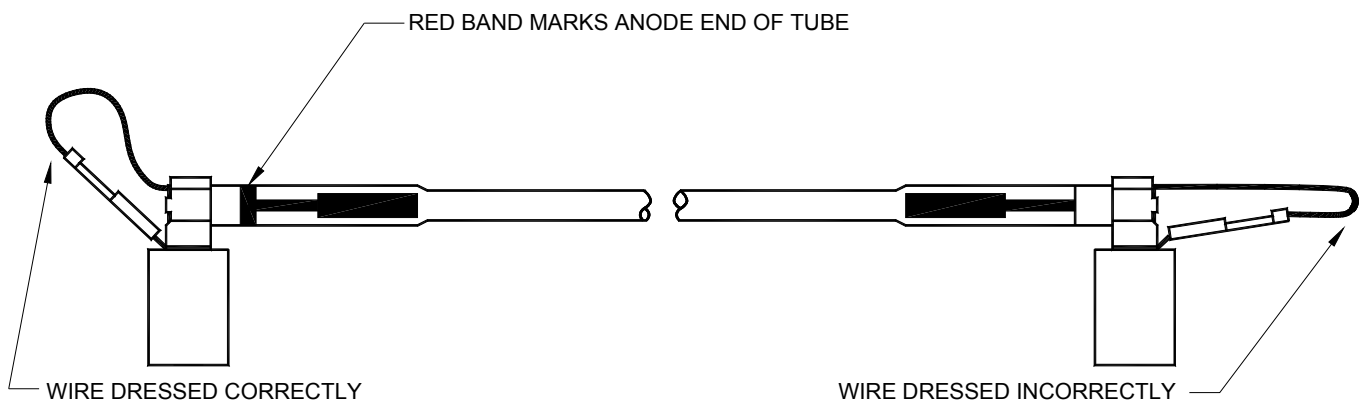

**Figure 3-1: Flash tube Installation**

### 3.3 Installation

#### 3.3.1 SGC-60 Master Controller

The Master Controller is connected to Flashheads via the data communications cable provided by Honeywell. The length of this cable (up to 2500 feet) determines how far the Master Controller can be mounted from the Flashheads.

A detailed drawing for mounting the Master Controller is shown in Figure 3-2, Page 3-8

#### 3.3.2 SGF-60E Flashhead

Normally the Flashheads are mounted at the uppermost point and additional referenced elevations on the structure. The Flashhead is connected to its Master Controller via the data communications cable provided by Honeywell. The length of this cable (up to 2500 feet) determines how far any Flashhead can be mounted from the Master Controller.

Honeywell labels all the Flashheads with numbers ranging from 1 to 24 depending on the number of required lights for the structure. Typically, the upper most level of lights will contain the lights with numbers 1 through 3 or 4. If the structure has an appurtenance of greater than 40 feet, an AOL (Antenna Obstruction Light) is required and it will have a Flashhead Number of 1. The High Intensity Flashheads will start with Flashhead Number 2. The Flashheads should continue down the tower from the top sequentially ending with the highest number at the bottom level.

The vent hole on the bottom surface of the power supply is covered with a solid plug prior to shipping. Optional screened plugs are furnished separately.

Typically, the Flashhead is mounted to a bracket, which is then attached to the structure. Honeywell can supply brackets for most types of installations.

A detailed drawing for mounting the Flashhead is shown in Figure 3-3, Page 3-9.

3.3.2.1 *Setting the Flashhead Elevation*

Flashheads must be mounted at the proper vertical angle to assure proper light output. Depending on the elevation of the light level, the Flashhead may need to be adjusted to reduce the amount of ground scatter. Please refer to the table below for proper elevation for the lights.

1. Slightly loosen the angle lock bolts, which are at the bottom of the mounting arms (see Figure 3-3, Page 3-9). The bolt heads and nuts fit 7/16" wrenches or nut drivers (tightening will require a pair of tools).
2. Adjust the Flashhead enclosure until the bubble indicator on top of the enclosure reads level.
3. Take note of the position of the bolt with respect to the silk-screened markings on the angle indicator. This position is the zero degree position. The markings are screened at intervals of one degree.
4. Adjust the Flashhead enclosure to aim the beam upward until the bolt head has shifted by the number of degrees indicated in the table below.
5. Securely tighten both angle lock bolts.

Light Unit Elevation above the Horizontal

Height of Light Unit Above Ground Level	Degrees of Elevation above Horizontal
More than 500 feet	0°
401 feet to 500 feet	1°
301 feet to 400 feet	2°
Less than 300 feet	3°

3.3.3 Ambient Light Sensor (Photocell)

The Ambient Light Sensor, when supplied with the system, shall be mounted upright, away from artificial light (e.g. floodlights), and in a location that will enable the sensor window to have an unobstructed view of the polar sky (pointed north in the northern hemisphere, not pointed toward the sun). The photocell housing wire entry is tapped to allow mounting to 1/2" threaded pipe. **Conduit and related hardware will be supplied by the customer.** A 21-foot 3-conductor cable is attached to the photocell for remote installation.

3.3.4 Cables and Junction Boxes

The cables shall be properly supported and terminated in the junction boxes per the detailed description provided in section 3.4, page 3-10 of this document. Additional information regarding cables and junction box installation can be found on the drawing set for the lighting system. Particular attention should be paid to assure that the data cable shields are isolated from the junction box housings.

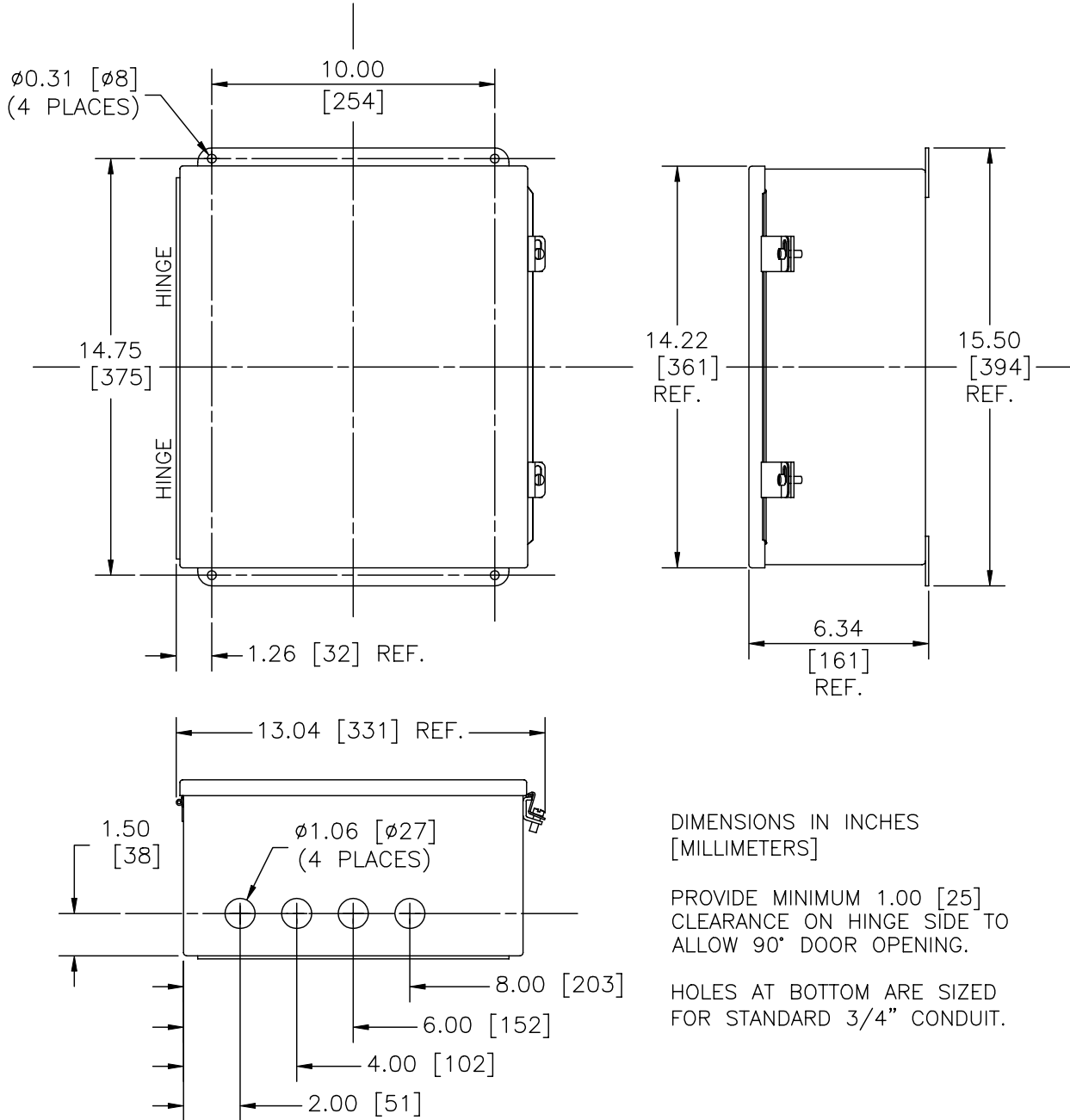
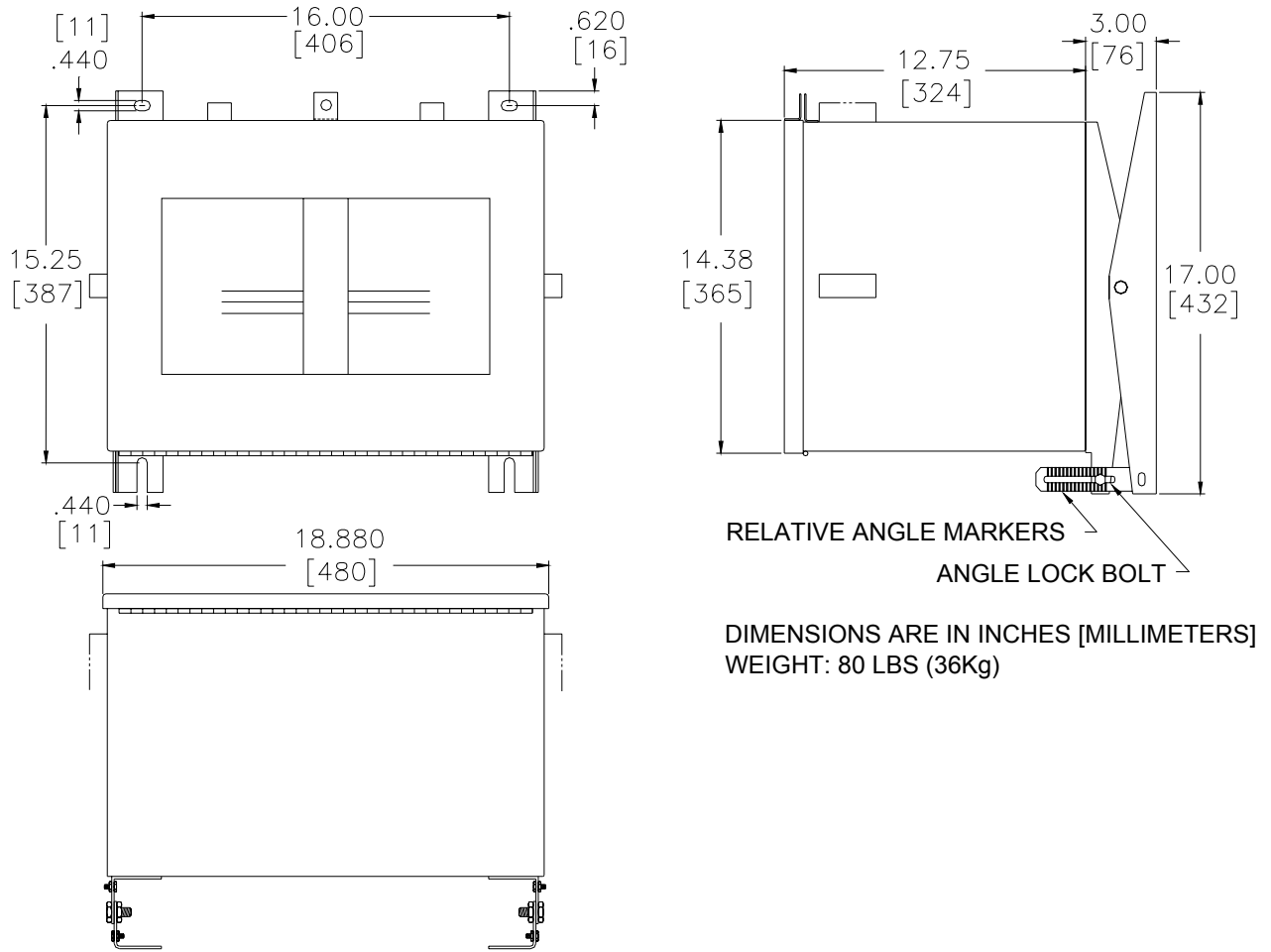

Figure 3-2: Master Controller Mounting Dimensions



**Figure 3-3: Flashhead Outline and Mounting Dimensions**



### 3.4 Installation Wiring

Follow the procedure below to perform the installation wiring. Note that the wiring of the Alarm Relay outputs is customer and site specific and is therefore not specified in this manual.

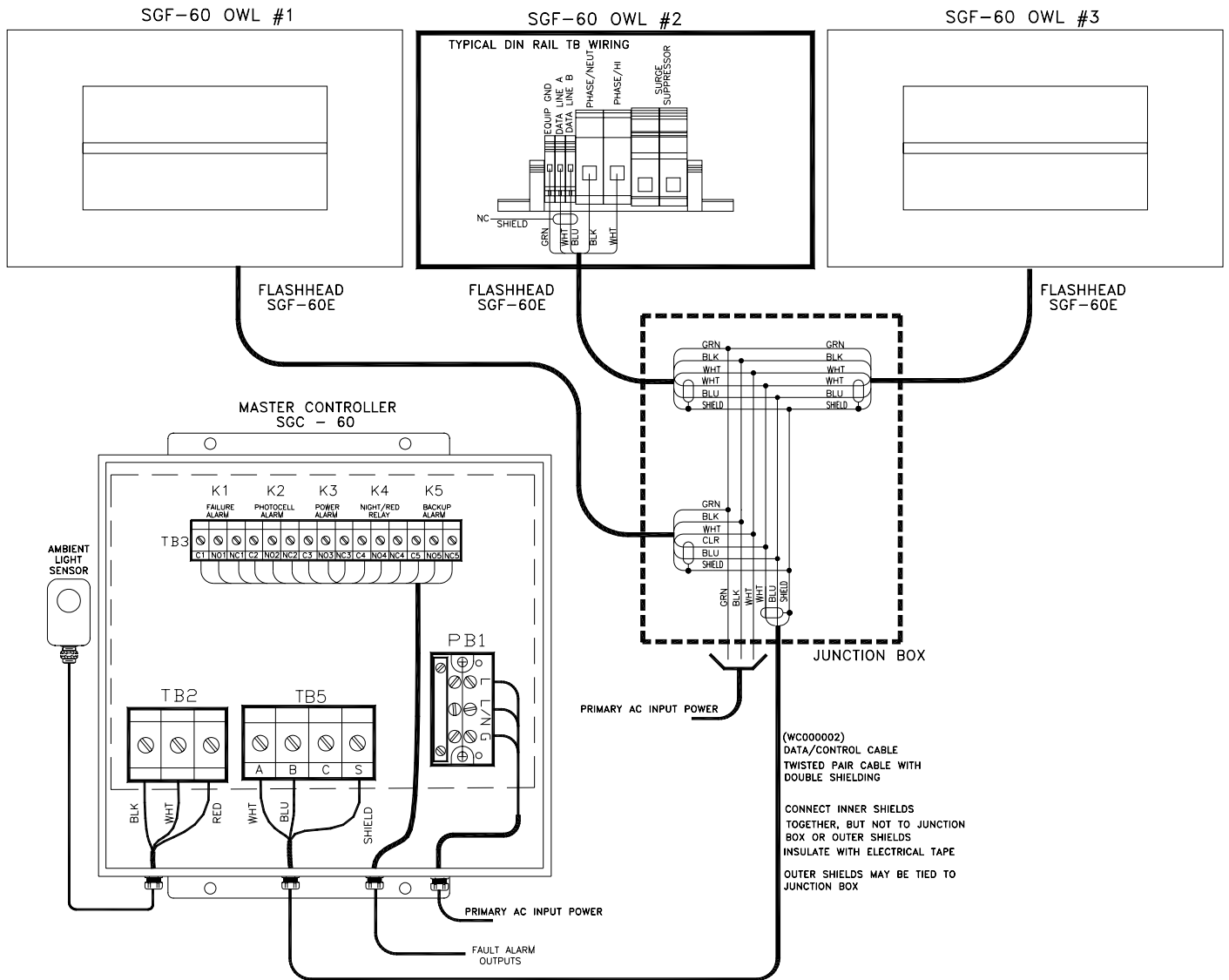

Figure 3-4: Typical Wiring Installation

3.4.1 Master Controller to Photocell Wiring

The photocell is supplied with a length of wire attached. If a longer wire is needed, this should be accomplished using a junction box. Make the interconnect between the external **Photocell** and the **Master Controller TB2** per Figure 3-4, Page 3-10, as follows.

**Black wire**      **Photocell** -----to----- **Master Controller TB2-B**  
**White wire**     **Photocell** -----to----- **Master Controller TB2-W**  
**Red wire**        **Photocell** -----to----- **Master Controller TB2-R**

3.4.2 Master Controller Data/Communications Wiring

Typically, the data/communications wiring is done with Honeywell P/N WC000002, a shielded, twisted-pair cable. It has one pair of conductors, and a drain wire for making shield connections. This cable is routed up the structure in the same conduit as the Flashhead power wiring. Connect the data cable wires to **Master Controller TB5** according to Figure 3-4, Page 3-10, and as follows:

**White or Clear wire** (Data signal "A")----- to ----- **Master Controller TB5-A**  
**Blue wire** (Data signal "B")----- to ----- **Master Controller TB5-B**  
**Shield drain wire** (Data shield) ----- to ----- **Master Controller TB5-S**  
(TB5-S is position 4)

The Data Shield (TB5-S) is grounded by the factory-installed wire that connects the E1 ground lug on the Master Controller circuit board to PB1-G.

If you need to connect a Flashhead directly to the Master Controller using the data cable integrated into Flashhead Cable WC000002, use the following connections.

**White or Clear wire**---- **Master Controller TB5-A** ----- to ---- **Flashhead TB1-4**  
**Blue wire**----- **Master Controller TB5-B** ----- to ---- **Flashhead TB1-5**  
**Inner Shield**----- **Master Controller TB5-S (4)** ----- to ---- **Flashhead TB1-6**  
**Outer Shield** ----- not connected at either end

3.4.3 Master Controller Power Wiring

Make the connections for incoming AC line power to **Master Controller PB1** per Figure 3-4, Page 3-10 as follows. These wires (or cable) are not supplied by Honeywell. A separate circuit breaker is recommended for the Master Controller. The Master Controller may, if desired, use a different AC line voltage than the Flashheads.

The wire colors below are typical for single-phase power. Be sure to check your own installation colors.

**Black wire** (Phase or hi) -----to----- **Master Controller PB1-L**  
**White wire** (Phase or neutral)-----to----- **Master Controller PB1-L/N**  
**Green wire** (Equipment ground) -----to----- **Master Controller PB1-G**

## 3.4.4 Master Controller Wiring for Dual Systems

If your installation is a Dual (Red/White) system, you must make additional connections to coordinate between the High Intensity Strobe System and the Red Light System.

See the sections below for wiring details. For configuration switch settings for a Dual system, see 3.2.1.3 on Page 3-2.

### 3.4.4.1 *Controlling the Red Light System*

The Master Controller uses Relay K4 to control the Red Light System. The Relay K4 contacts should be wired to the Red Light System in such a way that when K4 is **energized**, the Red Lights turn **off**, and when K4 is **de-energized**, the Red Lights turn **on**.

Typically this is done by disconnecting the Red Light System photocell, and wiring those photocell inputs to the Relay K4 contact. The contacts are rated for up to 5A, and up to either 30VDC or 250VAC.

If your red light system has a Honeywell 9LCA-Series Red Light Controller, the 9LCA photocell is not used. Instead of connecting the 9LCA photocell to 9LCA terminal TB3, make the following connections:

**Master Controller TB3-C4----- to ----- 9LCA Red Light Controller TB3-B**  
**Master Controller TB5-NO4 ----- to -----9LCA Red Light ControllerTB3-R**

Configure the 9LCA Red Light Controller to use Automatic mode control. Other Red Light Systems may require different connections. Refer to the Tower Kit drawing (if Honeywell provided both systems as a kit), refer to the Red Light System's manual, or contact Honeywell for assistance.

### 3.4.4.2 *Responding to Top Red Beacon Failures*

When a top-level red beacon fails at night, a Dual system must switch from red to white lights. The Master Controller will switch to the white strobes at night if it detects an open circuit between TB6-1 and TB6-2 ("EXT RED").

Install external wiring in a single electrical loop from TB6-1 to TB6-2 in such a way that the loop is **closed** when all the top-level red beacons are **operating correctly** and the loop is **opened** (broken) when any top-level red beacon **fails**.

The External Red Ready indicator (LED DS36 -- Item 10 in Figure 3-, Page 2-2) turns on to indicate a closed loop (Red Lights OK), and turn off to indicate an open loop (Red Light Failure).

If your red light system has a Honeywell 9LCA Series Red Light Controller, locate the Alarm terminals and Flasher Bypass terminals corresponding to the top beacon, and make the following connections:

**Master Controller TB6-1 ----- to ----- 9LCA Flasher Bypass C1**  
**9LCA Flasher Bypass NC1 ----- to ----- 9LCA Alarm Card C1**  
**Master Controller TB6-2 ----- to ----- 9LCA Alarm Card NC1**

Note: Usually the top beacon terminals are found on the top/left Flasher Bypass Card (TB4), and the left channel of the top Alarm Card (TB3).

Other Red Light Systems may require different connections. Refer to the Tower Kit drawing (if both systems were provided as a kit by Honeywell), the Red Light System's manual, or contact Honeywell for assistance.

3.4.5 Flashhead Wiring

Incoming AC power and data communications enter the Flashhead in a single cable, Honeywell P/N WC000001, that combines three wires for AC power with a twisted-pair/double-shielded data cable (See Figure 3-, Page 3-19). Typically, Flashheads are supplied with a 10-20 foot length of this cable already installed.

Should you need to install or replace this cable, make the connections for incoming AC power and data to **Flashhead TB1** per Figure 3-4, Page 3-10, and Figure 3-, Page 3-21, as follows.

- Green wire** (Equipment ground)----- to -----**Flashhead TB1-1**
- White wire** (Phase or neutral)----- to -----**Flashhead TB1-2**
- Black wire** (Phase or hi)----- to -----**Flashhead TB1-3**
- Data Cable**
- White or Clear wire** (Data signal "A") ----- to -----**Flashhead TB1-4**
- Blue wire** (Data signal "B") ----- to -----**Flashhead TB1-5**
- Inner shield** (Data shield)----- to -----**Flashhead TB1-6**
- Outer shield**-----trim short; not connected

3.4.6 Conduit and Tower Wiring Detail

This section details a standard practice of installing conduit and the related tower lighting wires for the system. Please use this guide to help install the wires into the conduit system. The wires and cables for the SG-60 High Intensity system need to be run properly to ensure that the system will work properly. Wire insulation that is damaged will lead to a system that will not function properly and may void the warranty. Ensure that the following procedure is followed. Pay close attention to all **bold** text.

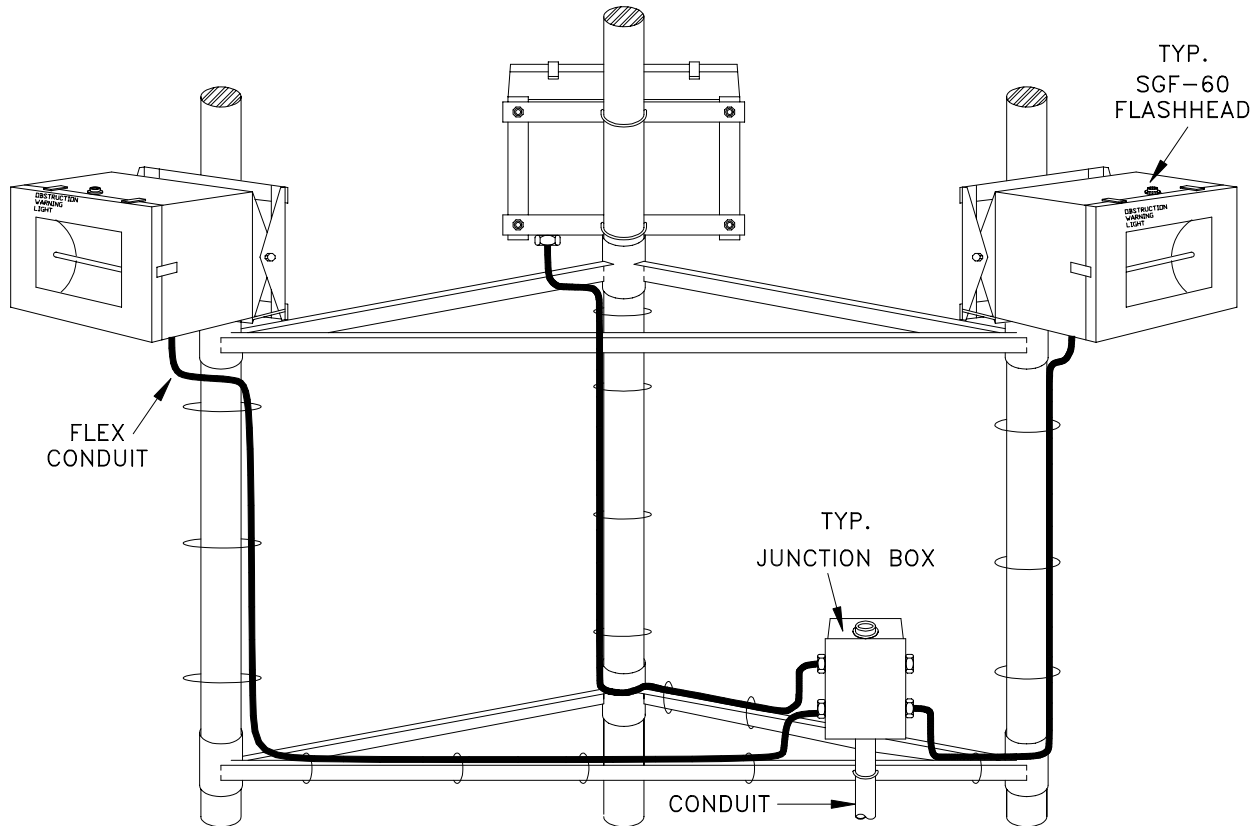

**Figure 3-5: Flex Conduit Typical Installation Layout**

3.4.6.1 *Procedures for installation of conduit and tower wiring*

1. All conduits, junction boxes, mounting hardware, fixtures, etc. provided for installation of the electrical system (i.e. lighting or equipment power distribution) should be inventoried and checked against the appropriate bills of materials.
  - (a) Conduit and junction box components provided for electrical systems should be checked against appropriate bills of materials to ensure all are present and of proper size.
  - (b) Numbers of wires to be carried by each conduit run should be checked against National Electrical Code. Honeywell sizes the conduit run for a 40% fill of the conduit by the NEC.
2. Use pipe compound or equivalent for all threaded connections in the conduit run. This will prevent water from entering the conduit system and make an electrical connection between the conduit and ground.
3. All custom cut pieces of conduit must be de-burred after they are threaded to remove sharp edges that may cut wiring insulation. Honeywell supplies conduit in 10-foot lengths, therefore cutting and threading of the conduit may be necessary.
4. Ensure that “chase nipples” or bushings are properly installed in all junction box ports to protect the wiring insulation from pipe threads and other sharp edges in the junction box ports. **Do not** begin to run wire through a junction box port before a chase nipple or grommet is in place.

5. **Before running the wire into a box ensure the wire insulation will be protected from any sharp edges on the junction boxes.** Pieces of carpet, wide copper braid, etc. can be fastened in place over sharp edges to protect wire insulation.
6. Precut and bundle method of wire installation:
  - (a) Cut all conductors to length for their respective run with adequate excess to allow for strain relief and additional slack for connections.
  - (b) Ensure that there is plenty of wire pulling lubricant on site before beginning to pull wiring. Use plenty of lubricant as the wire is being run through the conduit.
  - (c) The wiring bundle should be hoisted above the junction box at the top of the run into which it is to be inserted then lowered down into the conduit. **There should be someone at the top junction box of the run to ensure the wiring does not get scuffed or cut on junction box edges and to apply lubricant to the wiring as it enters the conduit.**
  - (d) If the conduit and wire will be installed on the ground, use the same methods described here. **Ensure proper amount of lubricant is available** and that the wire is shielded from any rough edges on the conduit or ground that might damage the wire/cable insulation.
  - (e) Adequate slack should be pulled back up into the uppermost junction box to effect strain relief and to make proper wiring connections. Once wiring bundle is supported by the strain relief mechanism, make all wiring connections in the junction box.
    - i. To make proper connections the wiring entering the box from above and the wiring above, the strain relief mechanism at the bottom of the box must be long enough. The wires at the top of the box should be formed into a “J” shape and the last 1/2-inch of insulation should be stripped off the conductor. The wires from the bottom of the box supported by the strain relief mechanism should be run up to a point just short of the top of the junction box and cut off. The last 1/2-inch of insulation should then be stripped from those. Wire connections should be made with proper sized Scotch® Twist wire nuts or split bolt connectors.
    - ii. Once a wire nut is installed, hold the wire nut and tug on all wires firmly to ensure the connection of all conductors is tight.
    - iii. Finish each connection with at least 6 wraps of Scotch 33+ tape or equivalent for proper moisture protection.
    - iv. When a proper connection is complete, the wire nut should be positioned upside-down (wire nut opening pointing downward) and the connection should be at the top end of the junction box. Wiring from ports in the sides of junction boxes should also be made such that the wire nuts are at the top of the junction box with the wire nut openings pointing downward, (see , Page 3-17) for proper moisture protection.

- (f) Move down to the next intermediate (strain relief) junction box and pull enough of the wiring into the box to provide for the proper installation of the strain relief mechanism.
- (g) Move down to the next intermediate junction box and repeat the above procedure until the entire tower is wired.

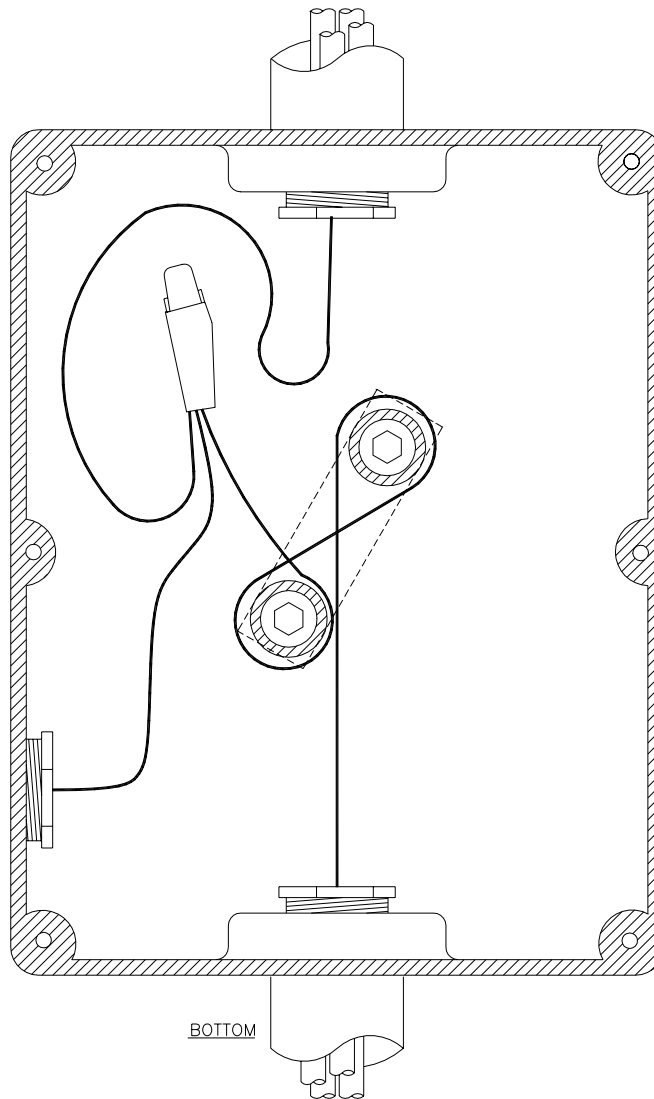

**Figure 3-6: Junction Box Wiring Detail**

### 3.4.7 Junction Box Details

This section will detail the proper wire interconnection details for the input voltage and data cable to the Flashhead pigtail cable. These connections are very important to the proper operation of the lighting system. The Flashhead pigtail contains all the wires required for proper interconnection between the conduit wiring and Flashhead.

Additional reference materials can be found on the High Intensity Lighting system drawing set. Please reference the below information and drawings for a proper installation. Mis-wiring of these wires will not allow the Flashheads to operate properly. Please call the Honeywell Technical Support if you have any questions regarding the installation of these connections. Systems that are improperly wired may void the warranty.

#### 3.4.7.1 *Flex Conduit Installation*

On each of the high intensity Flashheads, a pigtail is attached at the factory for installation to the junction box. This pigtail may not be long enough for proper routing along the horizontal and vertical struts on the tower. The high intensity lighting system will have a 100-foot spool of pigtail cable, Honeywell P/N WC000001, for installer to use for those Flashheads that do not have a long enough pigtail. If this spool of cable will not accommodate all the Flashheads, extra cable can be ordered from Honeywell.

The  $\frac{3}{4}$ " flex conduit will be used for shielding of possible RF Interference generated by some broadcast and radio towers. The conduit will be positioned over the Flashhead pigtail and connected at the junction box and Flashhead enclosure by watertight connector designed for the  $\frac{3}{4}$ " flex conduit. The installation will consist of the following materials:

- $\frac{3}{4}$ " Flex Conduit – Honeywell part number CL000002

- $\frac{3}{4}$ " Sealing Ring – P/N \*77-1085

- $\frac{3}{4}$ " Bushing Insulator – P/N \*77-1087

- $\frac{3}{4}$ " Flex Conduit Fitting – P/N CD000003

Consists of: Gland nut, body, edge cone, nylon seal ring, and  $\frac{3}{4}$ " locknut

Please reference Figure 3-, Page 3-18 for proper installation of this conduit.



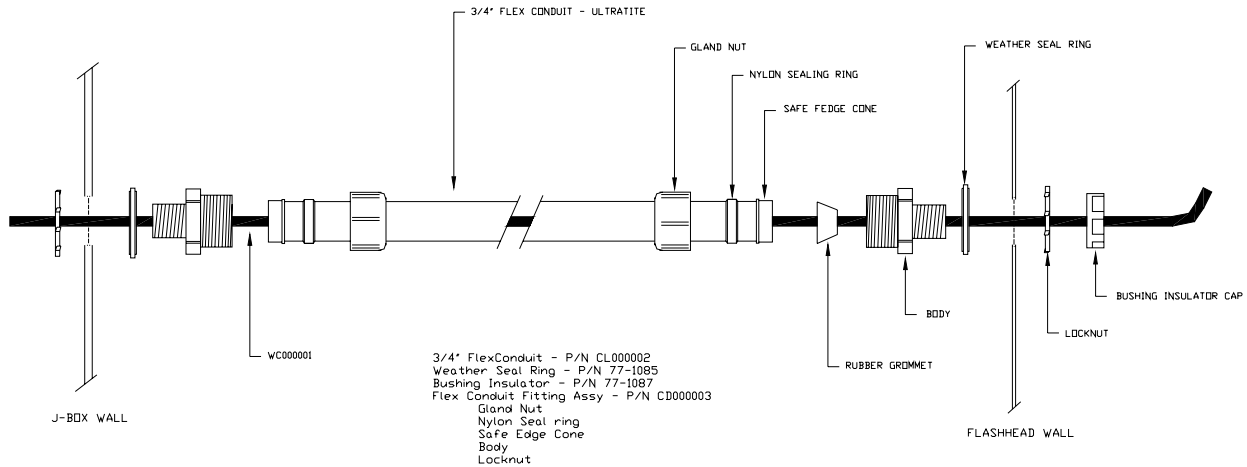

**Figure 3-7: Flex Conduit Installation Detail**

The flex conduit will need to be properly mounted to the horizontal and vertical struts by way of the supplied 20-inch cable ties. These cable ties should be placed at a minimum of 3 feet apart for proper bonding to the tower structure. The distance between the cable ties may need to be reduced if the installer sees that the 3-foot distance will not allow for proper bonding and securing to the tower.

Figure 3-5, Page 3-14 depicts a standard installation layout for the Flashhead pigtails and flex conduit.

**3.4.7.2 Splicing Details for WC000001 Cable**

The installation of the data/communication cable is the most important part of the High Intensity Lighting system installation. Without a sound connection for the data cable, the entire system will not work properly. Ensure that the following steps are followed to ensure a proper installation and connection.

**NOTE:** Splicing of the cables at any other location besides the light level is not recommended. The intermediate junction boxes between the light levels should be used as pull boxes and for strain relief only, with no splices.

The WC000001 cable is a multi-conductor cable that is used for the interconnection of the Flashhead to the junction box. The WC000001 cable consists of the following wires/cable:

CONDUCTORS			
ITEM NO.	WIRE		INSULATION COLOR
	SIZE	STRANDS/AWG	
1A	20 AWG	7/28	CLEAR
1B	20 AWG	7/28	BLUE
1S	20 AWG	10/30	BARE DRAIN WIRE
2	12 AWG	41/30	BLACK
3	12 AWG	41/30	WHITE
4	12 AWG	41/30	GREEN
5	14 AWG	41/30	BARE DRAIN WIRE
6	14 AWG	41/30	BARE DRAIN WIRE

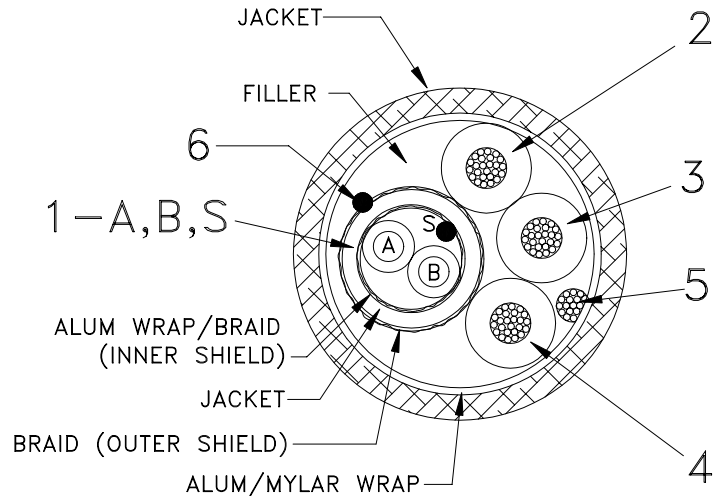

**Figure 3-8: WC000001 Cable Overview**

Item 1 (A, B, S) is the data/communication cable that is used to transmit all the data from the master controller, SGC-60, to the Flashhead, SGF-60E. Without a proper connection, the lighting system will flash erratically, or default to Day mode.

Items 2, 3, and 4 are used for the power input from the junction box to the Flashhead.

Item 5 is the Drain Wire for the outer cable shield.

Item 6 is a shield drain wire that will not be used for interconnection. This wire should be cut off flush from the cable when the outer jacket is stripped back for interconnection of the system.

The following section is a guideline to a proper installation of the WC000001 cable. Please follow this guideline to ensure a proper installation and interconnection in the junction box.

1. Strip back at least 16” of the outer jacket of the WC000001 cable. Make sure that during this removal, the other wires are not damaged. If the insulation is damaged on one of the other wires, a potential of lighting problems can occur shortly after the system is connected.
2. Remove all the aluminum foils and braids from the exposed conductors. These will **not** be used for interconnection.
3. Cut off Item #6, bare shield wire, that protrudes from the cable. This wire will **not** be used for interconnection.
4. Connect Item #5, bare shield wire, and Item #4, #12-AWG Green wire, from all the cables to the ground lug inside the junction box. This ground lug can be found on the back plane of the junction box or at an internal locknut that has a ground screw attached. No other wires will be connected to ground.
5. Connect Item #1S, data/communication inner shield drain wire, to the other data shield drain wires from the additional data cables. Trim back

the associated shield neatly. Make sure that this drain wire and the shield **cannot** contact the walls of the junction box or other wires. Do not connect inner shield to outer shield. Extra taping may be required for proper isolation. The inner shield should only have a connection to ground inside the SGC-60 controller.

On a typical installation, there will be a total of 5 wires that will be connected together. One from the lower junction box level, three from the Flashhead cables on that level, and one for the cable going to the next level.

6. Connect Item #1A to corresponding wires in other four cables as stated above in step 5.
7. Connect Item #1B to corresponding wires in other four cables as stated above in step 5.
8. Connect the #12-AWG Black and #12-AWG White wires as required by the installation drawing set supplied with the lighting system. If the system has a 3-phase input, ensure proper connection between the 3-phase wires (typically brown, orange, and yellow) and the black and white wires from the Flashhead. Proper load balancing is required on the three-phase input to operate efficiently (distribute the Flashheads as evenly as possible across the phases).
9. The power wires should be spliced together using split bolt connectors. The data wires should be spliced together using Scotch® Twist Lock connectors. After splicing, ensure all wires are secure by pulling on each wire. Wrap each connection with at least 6 wraps of Scotch 33+ tape or equivalent for moisture protection. All connection ends should be located in the upper corners of the junction box with all closed end of the connector pointing up.

Note: The Master Controller can operate from a different AC voltage than the Flashheads if desired.

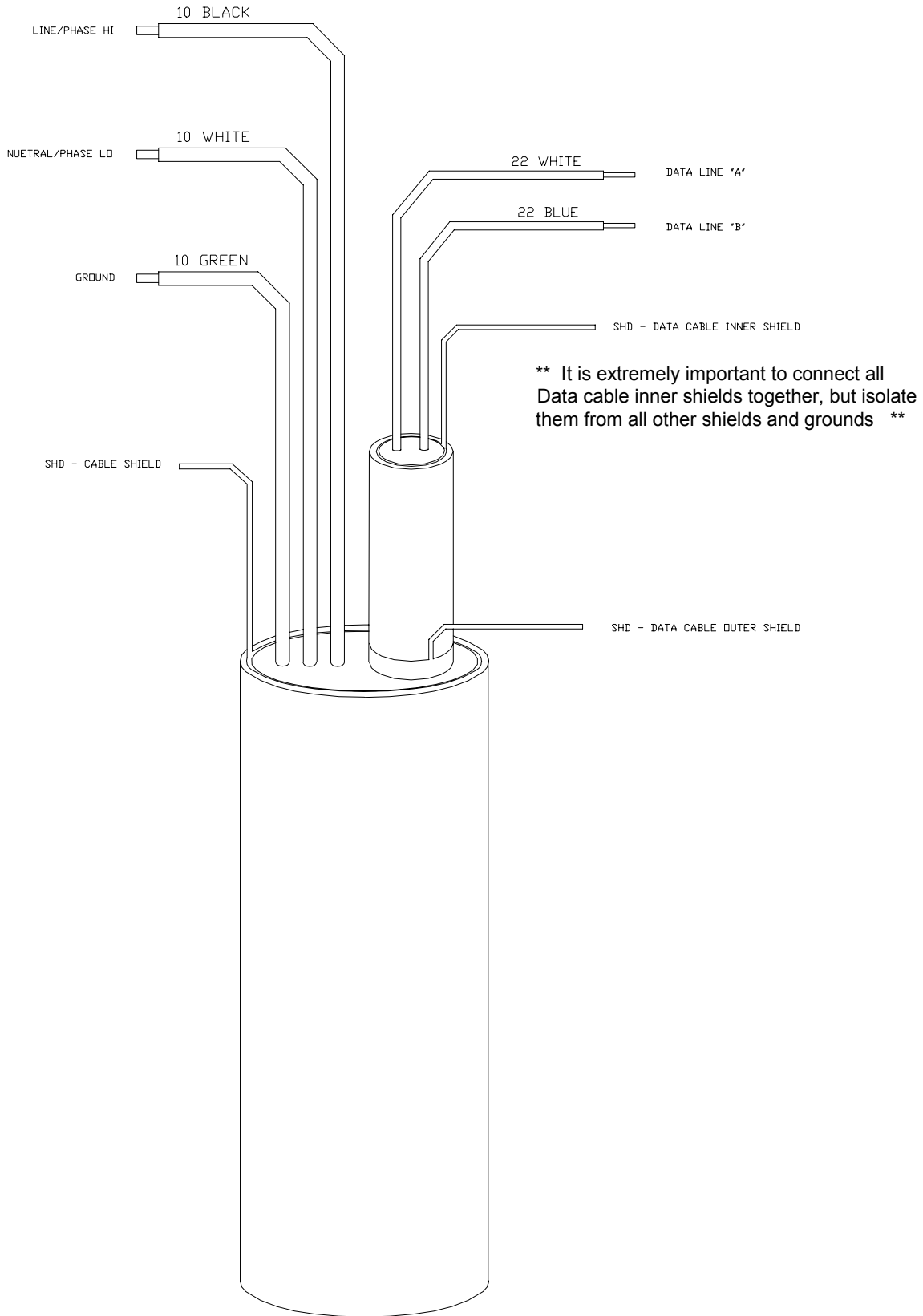

Figure 3-9: Flashhead Cable

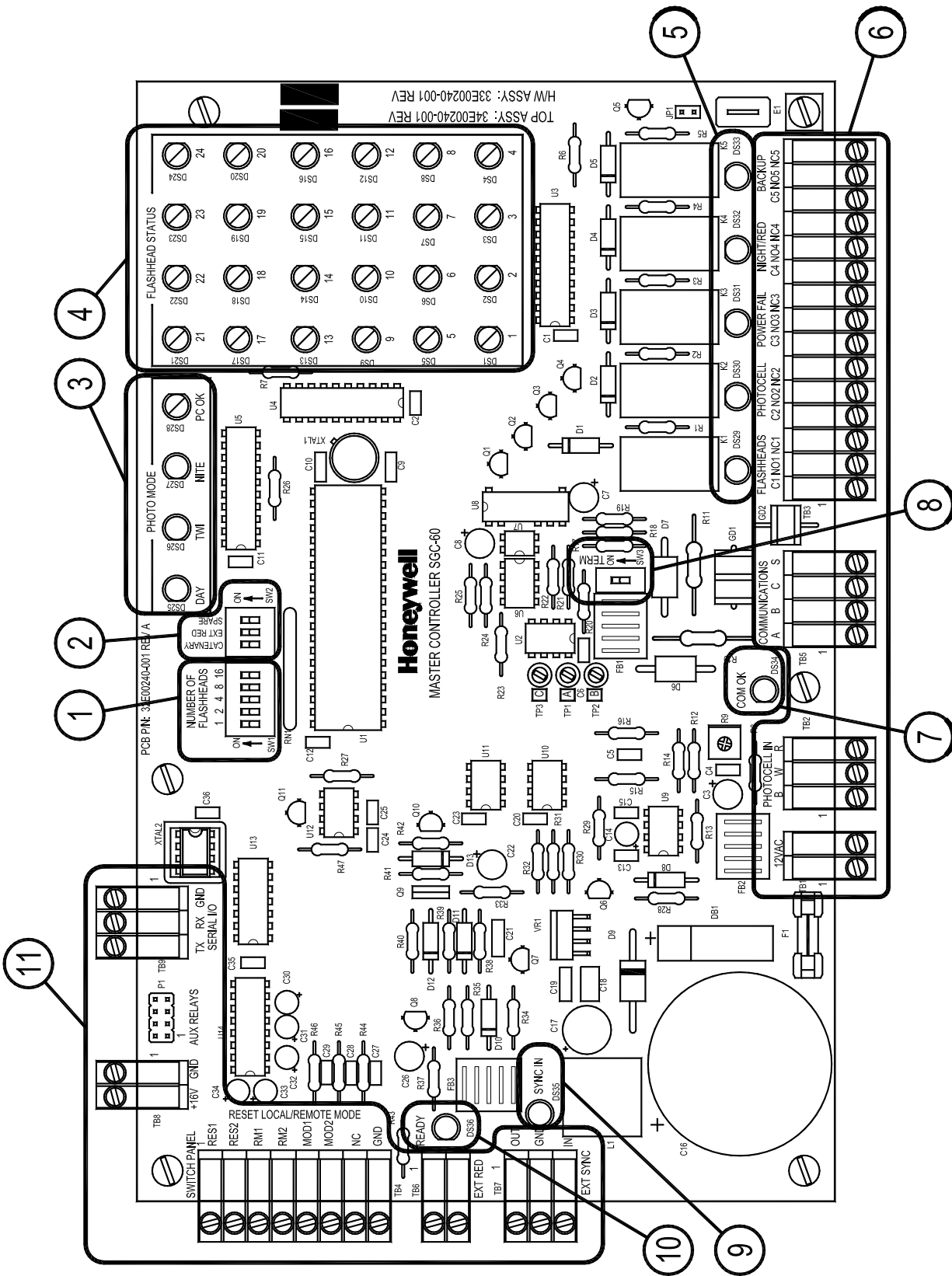

Figure 3-10: Master Controller Circuit Board

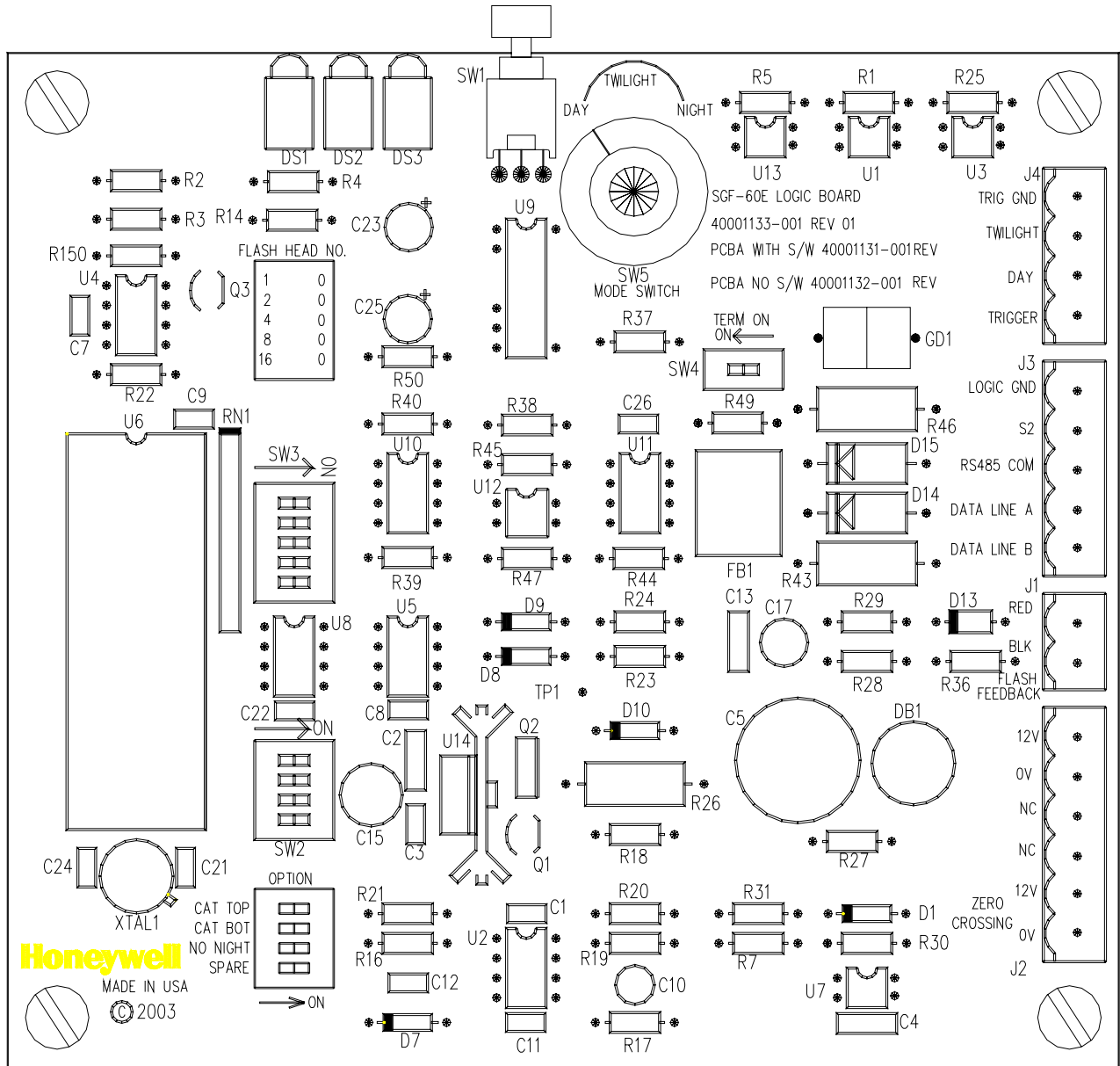

Figure 3-71: Flashhead Digital Control Board

**3.5 Final Installation Check**

Before applying power to the equipment, perform the procedures in Sections 3.5.1 - 3.5.4. If any test does not pass, please consult SECTION 5. TROUBLESHOOTING in this manual or call Honeywell Technical Support at (805) 581-5591.

**3.5.1 Preliminary**

1. Verify that all AC input power circuit breakers are turned off.
2. Check that all connectors to the printed circuit boards are properly seated in their sockets.
3. Check that any user-installed wiring does not interfere with relay operation when covers are closed.
4. Check that all Flashheads are mounted at the correct elevation per Section 3.3.2.1, Page 3-7. Check that all Flashhead covers are shut properly for a weather-tight seal with all latches closed.
5. Set Master Controller switches as follows:  
POWER SWITCH ----- OFF  
LOCAL / REMOTE Switch ----- LOCAL  
MODE Switch ----- DAY

**3.5.2 Verify Correct Wiring in Master Controller**

Verify correct wiring of the Master Controller as specified in Section 3.4, page 3-10.

**3.5.3 Verifying Photocell Wiring**

Verify correct wiring of the photocell as specified in Section 3.4.3, page 3-11.

**3.5.4 Verify Proper Tower Wiring for Data/Control Cable**

This test assumes a typical tower configuration with the data cable terminating at the Master Controller.

1. Unplug Data Cable connector TB5 from PCB1 in Master Controller.
2. Verify 120-140 ohms resistance between TB5-A and TB5-B on the Data Cable. (This checks that a single 100-ohm data line termination resistor is in the circuit. Resistance of 70 ohms or less indicates that more than one Flashhead has the terminating resistor switch set to on. See SW4 page 3-4.
3. Verify open circuit by measuring resistance between TB5-S on the Data Cable and panel ground.
4. Verify open circuit between TB5-A on the Data Cable and panel ground.
5. Verify open circuit between TB5-B on the Data Cable and panel ground.
6. Verify open circuit between TB5-S and TB5-A (both on Data Cable)

7. Verify open circuit between TB5-S and TB5-B (both on Data Cable).
8. In one of the top-most Flashheads, install a jumper (or alligator clip) between TB1-5 and TB1-6.
9. Verify short circuit between (<20 ohms) TB5-S and TB5-B (both on Data Cable).
10. Remove the jumper between TB1-5 and TB1-6.
11. Verify open circuit between TB5-S and TB5-B (both on Data Cable)
12. On the Master Controller card, measure between TB5-A and TB5-B and verify 120 ohms +/- 10% resistance. If not, check for proper configuration. See SW4 on page 3-4.
13. Plug Data Cable Connector TB5 back into PCB1.
14. Verify short circuit between TB5-S screw terminal and panel ground.

### **3.6 Power Up and System Tests**

During the power up of the system, there are indicator lights, which will be checked to verify correct operation and installation. The following is a description of all the indicators in the Master Controller and the Flashheads. The indicators in the Flashhead need not be checked unless problems are encountered during the normal power up tests.

#### **3.6.1 Master Controller Status Indicators**

- Photo Mode Indicators (Figure 3-, Item 3, Page 3-22)
  - DS25 – Red indicates active mode is Day
  - DS26 – Red indicates active mode is Twilight
  - DS27 – Red indicates active mode is Night
  - DS28 – Green indicates photocell is OK, Red indicates photocell is bad
- Individual Flashhead Status (Figure 3-, Item 4, Page 3-22)
  - DS1-24 – Green indicates Flashhead is good, OFF indicates Flashhead has not been selected for monitoring, Red indicates Flashhead is bad.
- Miscellaneous Indicators
  - DS34 – (Figure 3-, Item 7, Page 3-22) ON indicates transmit OK
  - DS35 – (Figure 3-, Item 9, Page 3-22) Flashing indicates sync input read OK.
  - DS36 – (Figure 3-, Item 10, Page 3-22) ON indicates red lights are available, OFF indicates red lights are reporting alarm or not installed



- DS32 - 33 – (Figure 3-, Item 5, Page 3-22) the indications on these lights are dependent on the setting for external red light system on SW2.  
*If SW2-2 is set for an EXTERNAL RED system (ON), then*
  - DS32 – ON indicates there has been a red light system alarm sometime during the night and the red light system is off, but will reset the next day. OFF when in night mode and the red light system is not in alarm
  - DS33 – ON indicates in night mode, red lights are turned off and white strobes are operating, OFF indicates NORMAL operation.*If SW2-2 is set for no EXTERNAL RED system (OFF) then*
  - DS32 – ON during DAY and TWILIGHT, OFF during NIGHT mode
  - DS33 - Not used (lower right of board)
- DS31 – (Figure 3-, Item 5, Page 3-22) ON indicates power OK, OFF indicates power failure
- DS30 – (Figure 3-, Item 5, Page 3-22) ON indicates photocell is GOOD, OFF indicates photocell is BAD or not connected
- DS29 – (Figure 3-, Item 5, Page 3-22) ON indicates all Flashheads are good, OFF indicates one or more Flashheads are bad

### 3.6.2 Flashhead Status Indicators

- Miscellaneous Indicators (Figure 3-7, Page 3-23)
  - DS1 Red ON for 5-Volt logic power OK
  - DS2 Yellow ON for Flash Current Feedback OK
  - DS3 Green ON Steady for communications OK (receive & transmit)  
OFF for no communications reception  
Slow Blink (1/sec) for receiving but not being addressed to transmit  
Fast blink (4/sec) for receiving, being addressed to transmit but failing to transmit

### 3.6.3 System Power Up

All switches and indicators listed in this section are in the Master Controller, except for the external system circuit breakers.

1. Verify POWER SWITCH is turned OFF.
2. Verify LOCAL / REMOTE switch is set to LOCAL.
3. Verify MODE switch is set to DAY.
4. Turn on circuit breaker to apply power to Master Controller.
5. Turn on circuit breaker to apply power to Flashheads.
6. Turn POWER SWITCH to ON.
7. Verify that the LED test sequence has started. The test sequence will exercise every LED and relay (e.g. it will quickly sweep through the

Flashhead Status LEDs in red and green mode).

After the test sequence completes, the Flashhead status LEDs for the selected number of Flashheads shall be lit red then change to green as the Flashheads report (DS1 - DS24, Figure 3- Item 4, Page 3-22).

8. After 1 minute, verify the number of Flashhead status LEDs (DS1 - DS24, Figure 3- Item 4, Page 3-22) that are lit green matches the total number of white Flashhead lights (including AOL) on the tower (if there are  $n$  Flashheads on the tower, Flashhead status LEDs DS1 - DS $n$  shall be lit green). Verify that the remaining unused Flashhead status LEDs (DS $n+1$  - DS24) are turned off.

Once all the Flashheads report good (green), the relay monitor LEDs should display as follows: DS29-DS32 GREEN, DS33 OFF (DS29 - DS33, Figure 3- Item 5, Page 3-22).

9. Verify Photocell status LED DS28 (Figure 3-, Item 3, Page 3-22) is lit green.
10. Verify Day Mode LED DS25 (Figure 3-, Item 3, Page 3-22) is lit red, and the Twilight and Night LEDs (DS26 and DS27 respectively (Figure 3-, Item 3, Page 3-22)) are not lit.
11. Hold down the RESET switch for approximately 1 second and verify the LED test sequence has restarted.
12. Wait 1 minute and measure the voltage between TB1-1 and TB1-2 to verify the voltage is 12-18 VAC. Repeat steps 7 - 10 to assure proper recovery after reset.

### 3.6.4 Verify Local Mode Operation

All switches and indicators listed in this section are in the Master Controller.

#### 3.6.4.1 *Day Mode:*

1. Verify MODE Switch is set to DAY.
2. Verify Day mode LED DS25 (Figure 3- Item 3, Page 3-22) is lit red.
3. After about 6 seconds, verify all Flashheads are flashing in sync and in Day mode (maximum brightness).
4. Verify that the Flashhead Status LED for each Flashhead on the tower is lit green (including any AOL). Unused Flashhead status LEDs shall be off. (DS1 - DS24: Figure 3-, Item 4, Page 3-22)
5. Verify relay status LEDs DS29-DS32 are lit green, and DS33 is OFF. (Figure 3-, Item 5, Page 3-22)
6. If you have a Dual (Red/White) System, the Red Lights should be OFF.
7. If you have a Catenary System, Verify Catenary flash timing.
  - (a) All Flashhead on Middle Level should flash together.

- (b) All Flashheads on Top Level should flash together
- (c) All Flashheads on Bottom Level should flash together.
- (d) Middle Level Flashheads should flash first.
- (e) Top Level Flashheads should flash second (1/13 second later)
- (f) Bottom Level Flashheads should flash third (2/13 second after Top)
- (g) Sequence should repeat every 1 second. (Time between Bottom and Middle flash is 10/13 seconds).

### 3.6.4.2 *Twilight Mode:*

1. Set MODE Switch to TWILIGHT.
2. Verify Day and Night mode LEDs (DS25 and DS27 respectively Figure 3-, Item 3, Page 3-22) are unlit and the Twilight mode LED DS26 is lit red.
3. After 6 seconds, Verify all Flashheads are flashing in sync and in Twilight mode (medium brightness).
4. Verify that the Flashhead Status LED for each Flashhead on the tower is lit green (including any AOL). Unused Flashhead status LEDs shall be off. (DS1 - DS24: Figure 3-, Item 4, Page 3-22)
5. Verify relay status LEDs DS29 - DS32 are lit green, and DS33 is off. (Figure 3-, Item 5, Page 3-22)
6. If you have a Dual (Red/White) System, the Red Lights should be OFF.

### 3.6.4.3 *Night Mode*

1. Set MODE Switch to NIGHT.
2. Verify Day and Twilight mode LEDs (DS25 and DS26 respectively (Figure 3-, Item 3, Page 3-22) are unlit and Night mode LED DS27 is lit red.
3. Verify that the Flashhead Status LED for each Flashhead on the tower is lit green (including any AOL). Unused Flashhead status LEDs shall be off. (DS1 - DS24: Figure 3-, Item 4, Page 3-22)
4. Verify relay status LEDs DS29-DS31 are lit green, and DS32 and DS33 are off. (DS29 - DS33: Figure 3-, Item, 5, Page 3-22)
5. If you have a White-Only System: After 6 seconds, Verify all Flashheads are flashing in sync and in Night mode (lowest brightness, ~1/8 second duration bursts at 40 bursts per minute).
6. If you have a Dual (Red/White) System: Verify normal red night mode operation.
  - (a) Verify that all Flashheads are OFF
  - (b) Verify that all Red Lights are ON and flashing properly, and the Red Light Controller does not indicate any alarms in the top-most Red Beacons.

- (c) Verify that LED DS36 (EXT RED READY) is lit green (See Item 10, Figure 3-, Page 3-22).
- 7. If you have a Dual (Red/White) System: Perform the following steps to check white night backup operation.
  - (a) Simulate a Top Red Beacon failure.
 

On a Honeywell 9LCA Series Control, this may be done with the B1 circuit breaker in the Control. Turn the B1 breaker off to activate the 9LCA Beacon Failure Alarm, or toggle the breaker momentarily to activate the 9LCA Flasher Bypass Alarm.

Other Redlight systems have different controls, and may require removing Red Beacon power at the input power circuit breakers.
  - (b) Verify that the DS36 (External Red Ready) LED is OFF.
  - (c) Verify that the DS32 (Night/Red) LED is ON
  - (d) Verify that the DS33 (Backup) LED is ON
  - (e) Verify that all the Red Lights are OFF
  - (f) Verify that all Flashheads are flashing in sync and in Night mode (lowest brightness, ~1/8 second duration bursts at 40 bursts per minute).
  - (g) Repair the simulated Red Beacon failure.
  - (h) Verify that DS36 (External Red Ready) LED is ON.
  - (i) Verify that the lighting system is still operating white strobes, and not red-lights.
  - (j) Set the MODE switch to DAY. Wait for the Flashheads to switch to DAY mode (about 6 seconds). Set the MODE switch back to NIGHT. Wait for the Flashheads to switch to OFF mode (about 6 seconds).
  - (k) Verify normal red night mode operation per Step 6 above.
  - (l) If you have more than one Red Beacon at the top level, repeat the simulated failure test for each Red Beacon.

### 3.6.5 Verify Photocell Operation Connected to Controller

1. Verify proper mounting and orientation of photocell. Photocell shall face toward the polar sky (e.g., North in the northern hemisphere), not toward the sun.
2. Set LOCAL / REMOTE switch to REMOTE.
3. Verify that the correct Mode status LED (DS25 - DS27 Figure 3-, Item 3, Page 3-22) is lit red according to the ambient light conditions (during normal daylight, DS25 shall be lit red).

4. Completely cover photocell (use a glove or hat, for example).
5. Verify Night Mode status LED DS27 is lit red.
6. Verify all other LEDs are in normal operating condition.
7. Verify that the Tower Lighting System is operating in normal night mode per 3.6.4.3. (Steps 2 through 6 only)
8. Uncover the photocell to expose it to ambient light.
9. Verify Mode status LEDs are in normal status for current ambient light conditions (during normal daylight, DS25 shall be lit red and DS26 and DS27 shall be unlit).

### 3.6.6 Verify Photocell Operation Not Connected to Controller

15. Disconnect connector TB2 from PCB1 in the Master Controller.
16. Verify all Flashhead LEDs (DS1 - DS24) are lit red.
17. Verify Photocell status LED DS28 (Figure 3-, Item 3, Page 3-22) is lit red.
18. Verify Photocell alarm LED DS30 (Figure 3-, Item 5, Page 3-22) is un-lit.
19. Verify all Flashheads are operating in Day mode (maximum brightness). The Flashheads will very slowly drift out of sync.
20. Reconnect connector TB2 to PCB1 in the Master Controller.
21. Verify that the Flashhead Status LED for each Flashhead on the tower is lit green (including any AOL). Unused Flashhead status LEDs shall be off. (DS1 - DS24: Figure 3-, Item 4, Page 3-22)
22. Verify Photocell status LED DS28 (Figure 3-, Item 3, Page 3-22) is lit green.
23. Verify Photocell alarm LED DS30 (Figure 3-, Item 5, Page 3-22) is lit green.

If the system passed all of the tests in Sections 3.6.3 - 3.6.6 above, the Master Controller, photocell and tower wiring were installed properly and the system is ready for normal operation. If any test did not pass, please consult SECTION 5. TROUBLESHOOTING in this manual or call Honeywell Technical Support at (805) 581-5591.

## SECTION 4. PRINCIPLES OF OPERATION

### 4.1 Overall Description

The SG-60 High Intensity Obstruction Lighting System meets the requirements of the FAA Advisory Circular 150/5345-43E. Depending on system configuration, the Flashheads are either type L-856 (simultaneous flashing, 40 flashes per minute (FPM)) or type L-857 (catenary flash pattern 60 FPM). The main components of the system are the Model SGC-60 Master Controller and the Model SGF-60E High Intensity Flashhead (with integrated power supply). Depending on tower configuration, a Medium Intensity Antenna Obstruction Light (AOL) may also be part of the system.

The Master Controller detects the ambient light conditions, controls the timing and intensity of the Flashhead flashes, monitors the Flashheads' operating status, and provides alarm and status information to the tower operator. See Figure 3-, Page 3-221.

The Flashhead produces a flash of white light from a xenon flash tube. The Flashhead Power Supply generates the high voltages and currents needed to trigger the flash tube and create the flash itself. The Flashhead Control Logic receives communications from the Master Controller, and sets the flash brightness and timing accordingly. The Flashhead Control Logic also provide a status reply when queried by the Master Controller.

The Master Controller and Flashheads communicate with electrical signals carried on a single twisted-pair cable (two signal conductors). Any transmission from either the Master Controller or a Flashhead uses both signal conductors together (only one device can be transmitting at any given time).

Both the Master Controller and Flashhead have override switches allowing the operator to select Day, Twilight, or Night Modes manually for test or troubleshooting purposes.

### 4.2 SGF-60E Flashhead

The main AC power input to the Flashhead is fed into the T1 Ferro resonant transformer. The input voltage selection can be configured for line voltages from 100V to 480V. The transformer has both regulated and unregulated outputs. The regulated output voltages consist of:

- 12V phase feedback to the logic board
- 400V center tapped output to the trigger board
- 870V<sub>RMS</sub> (1000V<sub>DC</sub>) and 1740V<sub>RMS</sub> (2000V<sub>DC</sub>) output to the HV board

The input to the Ferro is protected with surge suppressors and 2 line fuses, all mounted on the DIN rail terminal block TB1.

The High Voltage board rectifies the 1740V<sub>RMS</sub>, and, through series power resistors and relays, charges the energy storage capacitors to a DC voltage of 2000V. The flash tube V1, is always connected in parallel with the capacitors, but it is non-conductive until

triggered with a high voltage (10KV – 14KV) from the trigger board. The high amplitude trigger voltage will ionize the xenon gas in the flash tube, which will become conductive and discharge all the energy storage in the capacitors in the form of a bright flash of light.

As the capacitors' stored energy is depleted, the current flowing through the tube cannot sustain the arc, and the flash tube extinguishes, becoming non-conductive, and the cycle repeats itself.

Large capacitors store more energy and produce a brighter flash than smaller capacitors. For example, the brightest flash occurs when all the capacitors are tied together (K1 and K2 are de-energized) which corresponds to Day Mode. The lowest intensity flash (Night Mode) occurs when only the smallest capacitor is connected (K1 and K2 are energized)

As a safety feature, K3 relay will discharge the energy stored in the capacitors as soon as the case is opened, which opens the power interlock switch S1. Never rely solely on the K3 discharge relay, because if the safety discharge wiring became loose or damaged, the capacitors could still be charged to 2000VDC. Although the High Voltage indicator on the Trigger/High-Voltage is designed to indicate any high voltage still stored in the capacitors, you should always discharge the capacitors with an approved grounding rod before working with the system.

The Trigger Board draws 400V from the Ferro and generates a high voltage impulse of approximately 10KV to 14KV.

The unregulated outputs of the Ferro are:

- 12VAC
- 18VAC

and provide power for the digital circuitry, and the K1-K3 relays. It can accept a variety of input voltages depending on the primary tap connections, and it provides outputs of 12VAC and 24VAC. The T2 inputs are protected by fuse F2.

Logic circuits in the Flashhead receive command signals from the SGC-60 Master Controller. However, in the absence of command signals, the Flashhead generates its own timing signal, which controls the rate of flash.

Test switches located on the Flashhead switch assembly allow the system to operate in either Day, Twilight or Night mode. When the Flashhead door is closed, the system operates in Remote mode regardless of the switch positions. See Figure 2-2, Page 2-3.

**WARNING!**

**HIGH VOLTAGE is on the energy storage capacitors C1, C2, C3A and C3B when the High Voltage Indicator NE1 indicator is lit! (NE1 is the neon lamp located on the High Voltage & Trigger board - do not confuse the High Voltage Indicator NE1, with the PWR ON LED.)**

**It is possible to have high voltage on the energy storage capacitors even if all AC power has been removed from the system, even though the system is designed to drain the energy storage capacitors when power is removed.**

#### 4.2.1 SGF-60E Wire Harness

The Wire Harness has no active components. It provides the necessary connections between the external power and control wires and the Logic (Digital) and Trigger/High Voltage and Capacitor boards.

It provides connections for the Trigger/High-Voltage Board and the Digital Board . Most of the fast-on terminals (E1-E10) are used for high voltage and/or high-current connections.

#### 4.2.2 SGF-60E Digital Board

The digital board is responsible for coordinating all the activity within the Flashhead. The microcontroller U6 is the main processing units of the Flashhead. It receives, interprets, acts on, and replies to commands from the Master Controller. It also controls the energy selection relays, reads the manual mode select switches, controls the flash tube triggering, monitors the flash current. In the absence of any signals from the Master Controller, it will autonomously operate the strobe in Day Mode.

The following is a simplified sequence of events from the perspective of the Digital Board:

1. Wait to receive a flash request from Master Controller
2. Wait for next AC zero-crossing
3. Send trigger request signal to Trigger/High-Voltage Board
4. Check flash feedback current
5. Transmit a reply to Master Controller if the flash request was addressed to this Flashhead number and flash status is good.
6. Set K1, K2 Relays for next flash mode (Day, Twilight, Night)
7. Update Indicators DS2, DS3

The Digital Board functions are discussed in more detail below.



### 4.2.2.1 *Power Supplies*

The Digital board rectifies (DB1) and filters (C4) the 24VAC output of the Flashhead T2 transformer, and uses the resulting unregulated voltage to power the K1, K2, and K3 relays. The K3 relay coil is wired directly to this supply. K3 will be energized whenever power is supplied to the digital board. Power to the K1 and K2 relay coils is controlled by the micro-controller.

The unregulated power that feeds the relays is regulated by VR1 to +15VDC. This is used to power the logic and control circuitry on the Trigger/High-Voltage Board. (Connection between the boards is made by traces on the Motherboard.)

The Digital board also rectifies (DB2) and filters (C5) one of the 12VAC outputs of the Flashhead T2 transformer. This unregulated voltage is supplied to the power down circuit (described below), and VR2. VR2 provides regulated 5V power to the microcontroller and other logic chips. When 5V logic power is present, DS1 turns on (red).

The power-down circuit can briefly shut down the input to VR2, effectively removing all logic power from the board. The power-down logic has its own independent 5V power (using simple zener diode regulation of the DB2/C5 output). The shutdown circuit does not affect the relay or +15V supplies (although the K1 and K2 relays cannot be energized as long as the micro-controller is unpowered). You can test the function of the power-down circuit by pressing the S1 pushbutton for about 1 second. You should see DS1 turn off momentarily, and then as DS1 turns back on, you should see the LED check as the microcontroller software initializes (DS2 and DS3 should quickly blink together twice).

### 4.2.2.2 *Communications*

The Logic (Digital) Board receives commands from the Master Controller via an RS485 serial link. The RS485 transceiver chip U11 is protected from voltage transients by surge suppression devices and by transformer/optical isolation from chassis ground and the rest of the digital board.

If a voltage transient destabilizes the communications hardware or the main processor, the Digital Board will remove and restore its own logic power, thus clearing any momentary hardware (or software) faults. See 4.2.2.1 above for more information on the power down circuit.

SW4-1 (TERM) provides the necessary termination resistance for the RS485 serial network. Each end of the cable should be terminated with a resistor. Typically, only one Flashhead (one of the ones farthest from the Master Controller) will have SW4-1 set to ON. All other Flashheads will have SW4-1 set to OFF.

Every Flashhead must be assigned a unique address or ID (Flashhead number) from 1 through 24 inclusive, so the Master Controller can monitor the status of each individual Flashhead. The Flashhead number is set using SW3. Set the SW3 switches so that their total value equals the desired Flashhead number. The value for each switch position is shown on the board silkscreen. Note that ON means zero, and that OFF means the indicated value (negative binary).

The Digital Board will only transmit a reply when its number is specified by the Master Controller.

The Digital Board monitors its transmission quality by reading the transmission as it sends it. The green LED DS3 indicates the current communications status. It is updated after every flash. If no valid requests are being received from the Master Controller, the LED will stay off. If DS3 comes on, this indicates a valid data reception from the Master Controller. The DS3 flash pattern indicates the status of the most recent transmission from this Flashhead to the Master Controller. A "slow blink" indicates that no transmission has been attempted yet (status unknown). A "steady on" state indicates that the most recent transmission read back correctly. A "fast blink" indicates that most recent transmission failed to read back correctly.

The normal cycle on power up is: DS3 Off, then slow blink, then steady on. The duration of the "slow blink" period depends on the number of Flashheads in the system, as the Master Controller queries them in numeric order.

The Digital Board expects the Master Controller to request every flash. If the request does not arrive when expected, the DS3 will go out, and the DS3 status cycle will start over (transmission status will start as unknown).

If no flash requests are received from the Master Controller for 4 consecutive flash periods, the Digital Board considers that there has been a communications failure. If it has been at least 12 hours since power-on, it will use the power down circuit to reset itself. Otherwise it will switch the strobe to Day Mode.

For a Dual System, when the white lights are not flashing (at night), the Master Controller is still broadcasting regular flash requests -- but is requesting that the strobe flash in the "Off Mode."

#### 4.2.2.3 *Mode Selection*

If the Local/Remote switch is open (the spring-back position after being pushed in), the Digital Board will operate the strobe according to the position it reads in the Mode Select Switch. If the Local/Remote switch is closed (pushed in or pulled all the way out), the Digital Board operates the Flashhead in the mode requested by the Master Controller.

When the Master Controller requests a change in mode, there will be a 4-flash delay before the Flashheads update their own remote mode selection to match the requested mode.

If the SW2-3 (NO NITE) is set ON, the Digital Board will not flash at all in night mode. This option is provided for backward compatibility with Dual Systems with older Master Controllers installed that cannot broadcast an "Off" mode. In these older systems the Flashheads were configured so as not to flash at night, when the Red Lights were switched on. This option should not be used with the Master Controller described in this manual. Instead, configure the Master Controller to work with a Dual System.

#### 4.2.2.4 *Flash Control*

To fire the flash tube, the Digital Board pulls down the trigger request line (P2-17) for about 500uS. This signals the Trigger/High-Voltage Card to trigger the flash tube.

The Digital Board will issue its trigger request on a T2 zero-crossing. (Normally, the first zero-crossing it detects after receiving a flash request from the Master Controller.) In Day and Twilight modes, the Digital Board will issue a single trigger request. In Night mode, the Digital Board will issue a series of 15 pulses at consecutive zero crossings.

The zero crossing is determined from a 12VAC output from Flashhead transformer T1. As a failsafe measure, the Digital Board will issue a trigger request after a timeout period even if no zero crossing is detected.

When acting as a Top or Bottom Catenary Flashhead, the Digital Board will delay by 1/13 and 3/13 seconds respectively before looking for the first T2 zero-crossing, to achieve the required Catenary flash sequence:

The SW2-1 and SW2-2 switches instruct the Digital Board to apply the correct timing delays for Catenary Systems. The faster flash rate (60 flashes per minute) is set by an option on the Master Controller (SW2-1).

#### 4.2.2.5 *Flash Feedback*

The Logic (Digital) Board monitors the current discharged through the flash tube with the Flashhead current sense transformer T3. The T3 output is used to peak-charge a capacitor C17. The microcontroller reads the captured voltage level at the capacitor with A/D converter (U5) before and after the flash to determine if the flash occurred successfully. C17 will fully discharge before the next flash.

The yellow LED DS2 indicates the results of the most recent flash. If the Digital Board considered the flash successful the DS2 will be on. If the Digital Board considers the flash to have failed, DS2 will be off.

If four consecutive flashes fail, the Digital Board reports a Flash/Fail alarm to the Master Controller (per FAA specifications).

The T3 transformer connections are polarity sensitive. If the wires are reversed, the Digital Board will not be able to detect good flashes, especially in Day and Twilight modes.

#### 4.2.3 SGF-60 Trigger/High-Voltage Board

The Trigger/High-Voltage combines two completely independent functions: high voltage rectification and flash tube triggering.

##### 4.2.3.1 *High Voltage Rectification*

This section of the Trigger/High-Voltage Board provides the DC to charge the energy storage capacitors that power the flash tube.

The high voltage AC from the Ferro resonant power transformer T1 is output to the Trigger/High-Voltage board through the Flashhead ferroboard pins 0V, 1740 and 870V, respectively. The high-power diode bridge DB1 rectifies the incoming 2000Vp-p voltage to pulsed 2000VDC. This DC voltage is sent to charge the energy storage capacitors through Flashhead wire harness pins E6,E7 and E8 A Current Limiting Resistor with a series neon lamp, High Voltage Indicator NE1, is connected to the bridge output. High Voltage Indicator NE1 lights whenever high voltage is present.

### 4.2.3.2 *Flash tube Triggering*

The trigger control section receives +15V power from the Digital Board. The Digital Board also provides the trigger request signal telling the Trigger/High-Voltage Board to fire the flash tube.

The heart of the Trigger circuit consists of a trigger capacitor C1, SCR Q5, and driver transistor Q1. The trigger circuit energy is derived from terminals J1-1 and J1-3 of the main power transformer, through rectifiers D2, D3. This trigger energy is stored in a 0.5 $\mu$ F capacitor C1, whose charge path is through the primary coil of the high voltage trigger transformer T1 to ground.

The Logic Board sends a request for flash to the trigger board through pin J2-1, which turns SCR Q5 ON through Driver Q1, switching 0.5 $\mu$ F capacitor C1, charged to 450 volts, into the primary coil of the series trigger transformer T1, located on the flash tube assembly. The series trigger transformer T1 induces a 15KV pulse, triggering the flash tube. As the capacitor discharge current drops to zero, the inductance of T1 will force it to continue in the negative direction, causing SCR Q4 to turn OFF and allowing capacitor C1 to charge again in time for the next flash request.

## 4.3 SGC-60 Master Controller

### 4.3.1 Power Supply

The Master Controller input power is connected to PB1, which then feeds transformer T1 (under the switch panel). The Master Controller can accept a number of input voltages, depending on the primary tap connections to T1, and will operate at 50 or 60 Hz. The T1 transformer output provides 12VAC to the Master Controller circuit board PCB1 (T1-17 and T1-18 connecting to PCB1 TB1-1 and TB1-2). The input voltage passes through fuse F1, is rectified by DB1, and filtered by C16.

This unregulated voltage (about 16VDC) is available for external use TB8. The 16VDC is also fed into the switch mode power supply (including voltage regulator VR1), which provides regulated +5VDC to the rest of the board.

The 16VDC is also used to provide power for the power-down circuit. The power-down circuit can briefly shut down the regulated +5VDC supply powering the rest of the board logic, providing a power-on reset for the rest of the board logic.

The power-down circuit will be activated automatically if (1) the microcontroller stops functioning normally, or (2) the microcontroller detects a severe communications failure. To prevent nuisance alarm chatter, the microcontroller will only deliberately activate the power-down circuit if at least 24 hours have elapsed since the last power on.

The power-down circuit is intended to allow automatic recovery from rare cases when transients lock up the communications transceiver, but it can also be used as a manual board reset. . You may test this function by holding down the RESET toggle switch on the switch panel for about 1 second.

If input power is lost, or fuse F1 is blown the Power Fail Relay (K4, terminals TB3-C3, -NO3, -NC3) will de-energize.

### 4.3.2 Flash Requests and Flashhead Status

The Master Controller transmits a flash request command to the Flashheads every 1.5 seconds (or every 1.0 seconds in Catenary mode, selected with SW2-1). The flash request also contains the requested operating mode. The flash request applies to all Flashheads, but is addressed to a specific Flashhead.

All Flashheads receive the flash request. All Flashheads flash in response to the request, and update their operating mode, but only the addressed Flashhead may reply to the Master Controller.

Whenever a the Flashhead replies OK, the Master Controller marks it as good, and sets the corresponding Flashhead Status LED to green.

If the Flashhead does not reply OK, the Master Controller marks it as bad, and sets the corresponding Flashhead Status LED to red.

The Master Controller gives previously good Flashheads four chances to reply (addressing that Flashhead repeatedly), before marking them bad. Previously bad Flashheads are given one chance to reply OK before moving on to the next Flashhead.

The Master Controller checks the status of each Flashhead in order of increasing Flashhead number, cycling repeatedly through the total number of selected Flashheads. You can set the number of Flashheads monitored using DIP Switch SW1. If the Master Controller is not monitoring a Flashhead, the corresponding Flashhead Status LED is turned off.

If any Flashhead is marked bad (Red LED), the Master Controller will de-energize the Flashheads Alarm Relay K1 (TB3-C1, -NO1, -NC1), and turn off the corresponding LED (DS29).

### 4.3.3 System Mode Selection

The master controller determines what mode to transmit with the Flash Request by reading the Photocell input and the Front Panel Switches.

If the Remote/Local Switch on the front panel switch is set to Local, the Master Controller will take its operating mode from the position of the Local Mode Select Switch (Day, Twilight, or Night).

If the Remote/Local Switch is set to Remote (Photocell), the Master Controller will take its operating mode from the analog reading of the photocell input to TB2 of the Master Controller Board. If the photocell fails, the Master Controller will automatically select Day Mode.

The Master Controller indicates its current Photo Mode by illuminating the Day, Twi, or Nite LEDs (DS25-DS27). If the Photocell fails (including open or short circuit), the PC OK LED (DS28) will turn red, and the Photocell Fail Relay (K2) will de-energize. If the photocell status is good, DS28 will be green and K2 will be energized.

If the Master Controller is configured for a Dual System (SW2-2 is On), uses the K4 relay to control the Red Light Controller. The Master Controller energizes K4 to turn the Red Lights off, and de-energizes K4 to turn the Red Lights on. As long as the Red Lights are operating normally, the Master Controller will request Off Mode from the Flashheads instead of Night Mode.

If the Red Light Controller signals a top beacon failure (by creating an open between TB6-1 and TB6-2), the Master Controller will request Night Mode from the Flashheads, and energize K4 to turn off down the remaining Red Lights. The Master Controller also energizes K5, the Backup Relay, to provide an indication that the Dual system has switched to White Night Backup.

Once the Master Controller has switched into White Night Backup, it will remain latched in that mode until switched into Twilight or Day Mode (either automatically or manually). If the Red Light Controller indicates it is ready (DS36 is lit) at the next transition to into Night Mode, the Red Lights will be tried again. Typically, Red Light Systems (such as the Honeywell 9LCA series) do not report any Beacon Failures during the daytime. In this case, the Master Controller will briefly try the Red Lights each night until the top beacon is repaired.

Troubleshooting Tip: To check system communications independent of most Flashhead failures, place a jumper across TB6-1 and TB6-2, set SW2-2 On, and select Local Night Mode from the switch panel. Because an Off Mode "flash" cannot fail, all the Flashheads will reply OK if they can. Be sure to restore your Master Controller to its proper configuration after testing.

#### 4.3.4 Communications Circuitry

The Master Controller transmits its flash requests, and receives replies via an RS485 serial link. The RS485 transceiver chip U2 is protected from voltage transients by surge suppression devices and by transformer/optical isolation from chassis ground and the rest of the digital board.

The microcontroller (U1) monitors its own transmissions. After each transmission, the COM OK LED will be lit green if the transmission read back properly, or turned off if there was a read-back failure. This only indicates that the transceiver chip on the Master Controller is functioning properly -- it does not indicate that the Flashheads are communicating properly.

SW3-1 (TERM) provides the necessary termination resistance for the RS485 serial network. Each end of the cable should be terminated with a resistor. Typically the Master Controller is installed at one end of the communications cable, in which case SW3-1 should be ON.

The Master Controller board also provides the ground connection for the communication cable shielding. The shield drain wire terminates at TB5-S (position 4), and a heavy trace on the circuit board connects the shield to the lower right mounting screw, and fast-on connector, both marked E1. The factory installs a grounding wire from E1 to PB1-G. This should be the only place the communications shield is grounded. You can check this by unplugging TB5, and measuring for an open circuit between the (unplugged) TB5-S screw terminal and earth ground.

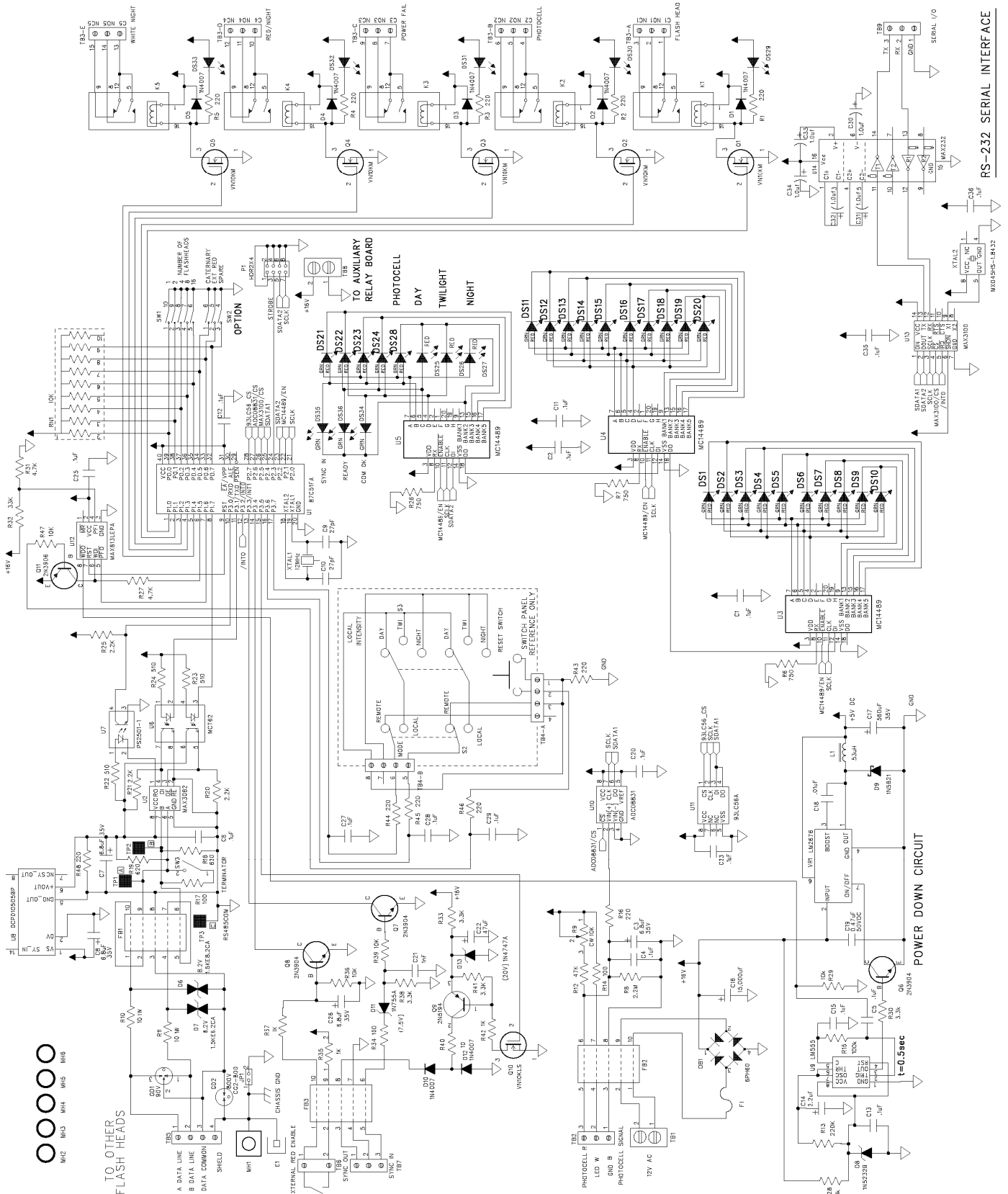

Figure 4-1: Master Controller Board Schematic

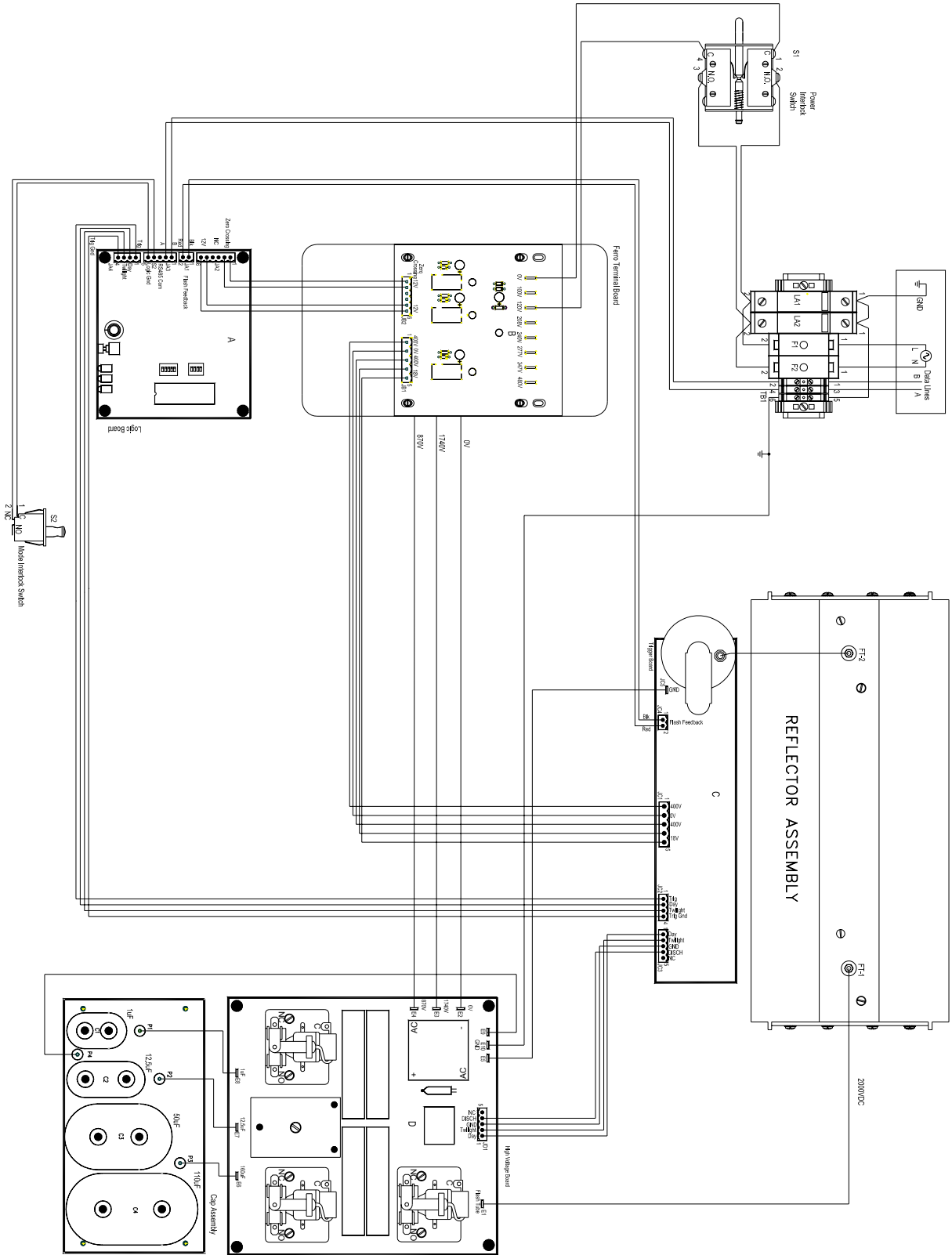

Figure 4-2: SGF-60E Flashhead System Schematic



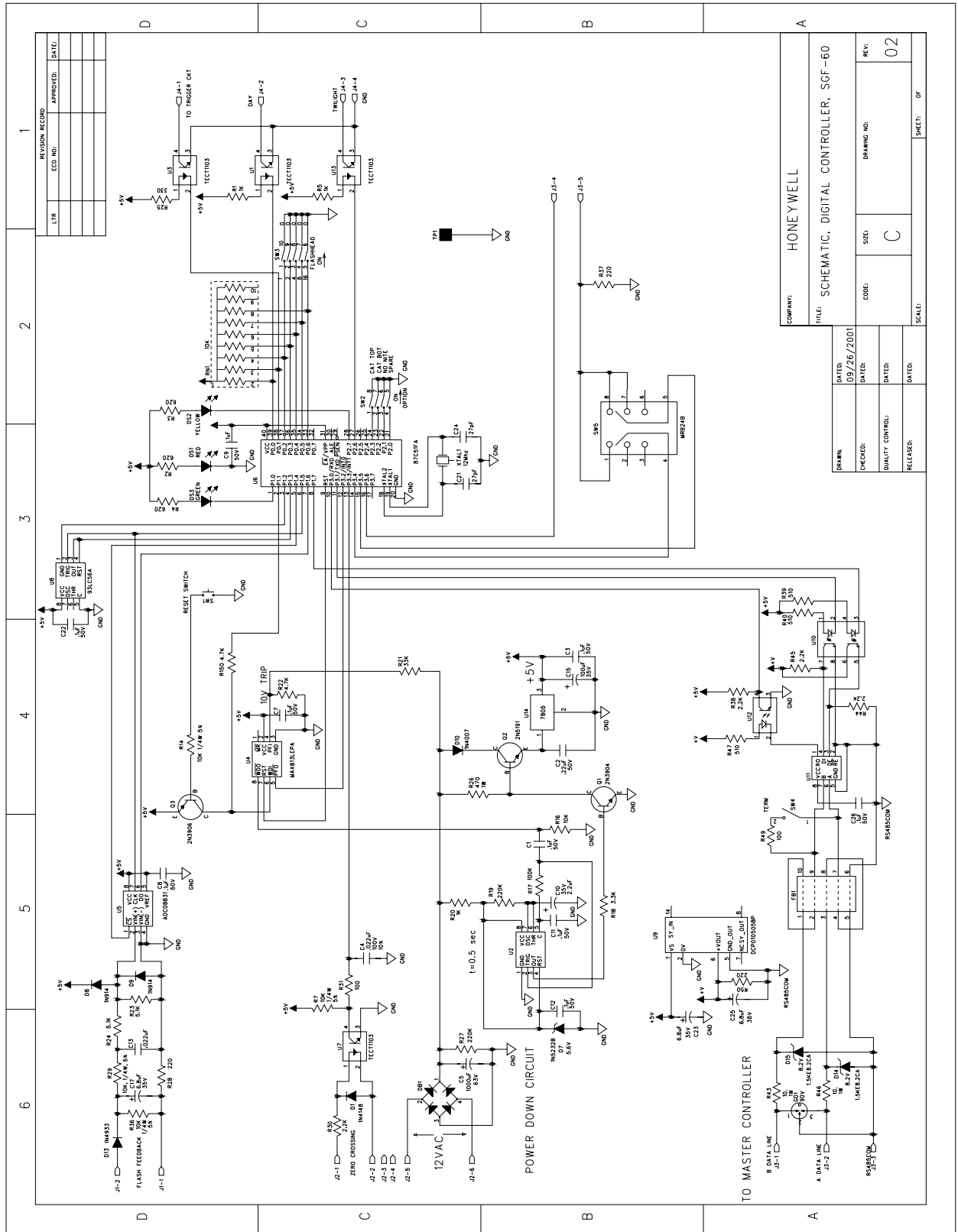
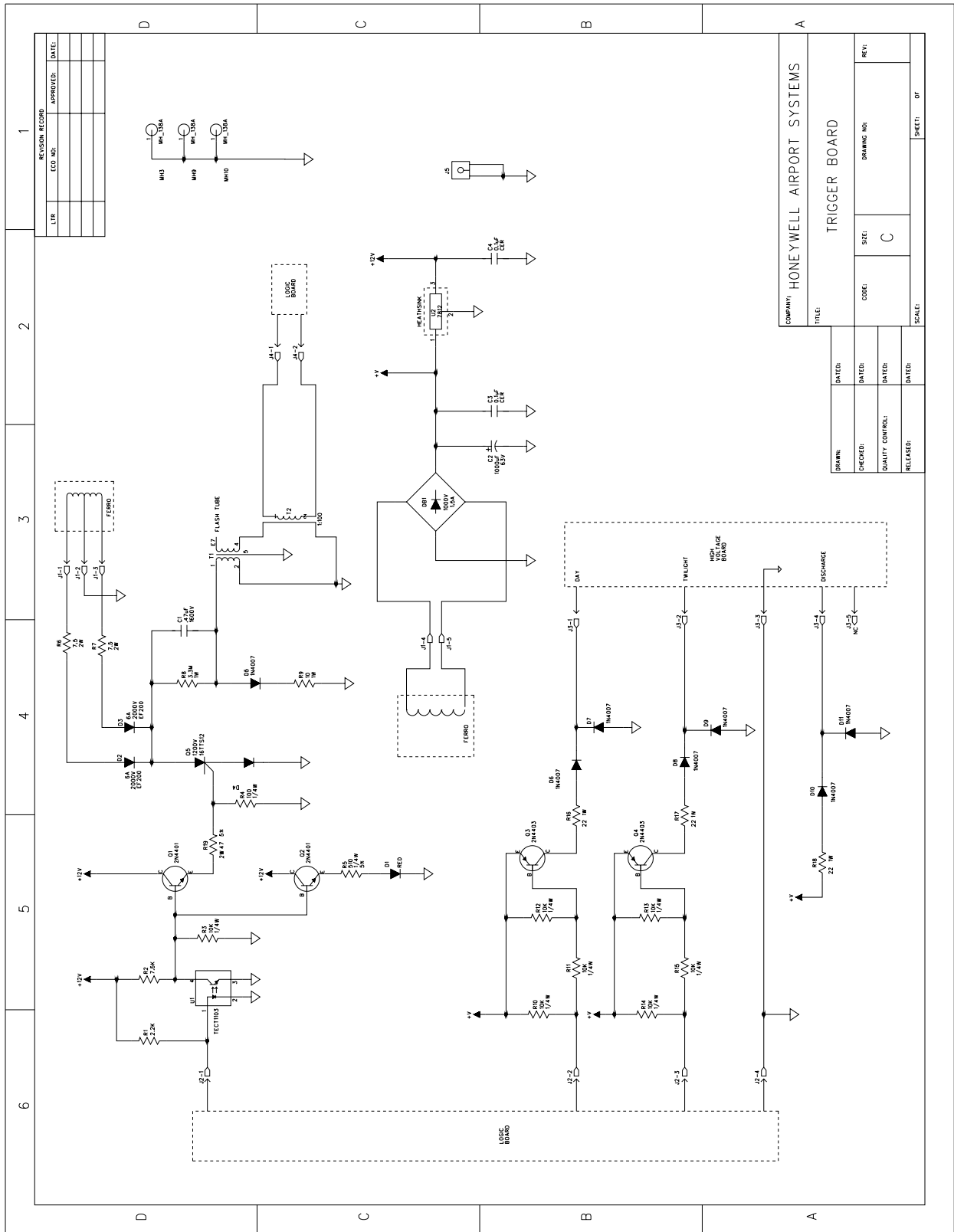

Figure 4-3: SGF-60E Digital Board Schematic



COMPANY: HONEYWELL AIRPORT SYSTEMS	
TITLE: TRIGGER BOARD	
DATE:	DATE:
CHECKED:	DATE:
QUALITY CONTROL:	DATE:
RELEASED:	DATE:
SCALE:	SCALE:
CODE: C	DRAWING NO.:
SIZE: C	REV.:
SHEET: 01	OF:

Figure 4-4a: SGF-60E Trigger Board Schematic

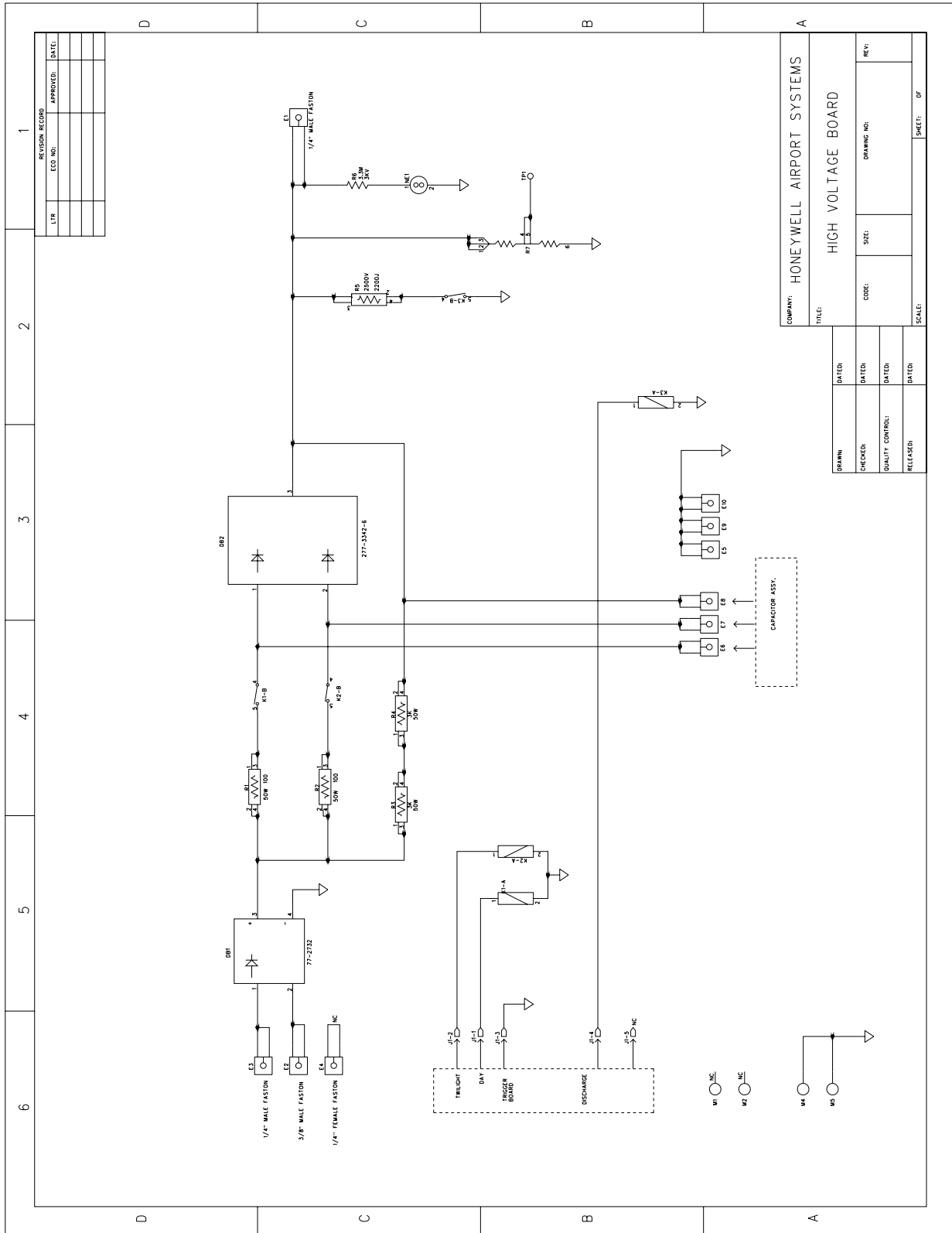

Figure 4-5b: SGF-60E High-Voltage Board Schematic

**SECTION 5. TROUBLESHOOTING**

Refer to the troubleshooting flowcharts. Replace components in the order stated, and keep track of those replaced. The following troubleshooting procedures presume that all fuses, interlocks, and controls are functioning properly. Note that the troubleshooting flowcharts are intended to be used as a general guide, and do not cover every possible mode of failure.

**WARNING!**

- 1. Always turn off power when changing any component or printed circuit board.**
- 2. High voltage is present in the Flashhead. Do not cheat the interlocks.**
- 3. Do not put hands or tools in the Flashhead until the High Voltage Indicator neon lamp NE1 on the High Voltage & Trigger board is extinguished. Refer to page 2-3 for the location of High Voltage Indicator NE1 - do not confuse the High Voltage Indicator NE1, with the PWR ON LED. Note that it is possible for the High Voltage Indicator NE1 to be lit even when the PWR ON LED is OFF. If this happens, the energy storage capacitors C1 - C3 must be discharged before performing maintenance.**
- 4. Do not look directly into the Flashhead at close range when it is flashing. Flash tubes in this lighting system produce brilliant flashes of light containing some ultraviolet radiation, which can cause temporary or permanent eye damage.**
- 5. The components and assemblies in this system were designed by Honeywell to handle the high voltages that are present. Honeywell strongly recommends against substituting components or assemblies that might be available through other vendors.**

Before consulting the troubleshooting charts, check the following.

- The Master Controller Local/Remote Switch is in Remote (Photocell)
- If you have a Dual System, check that the Red Light Controller is also set for Automatic Mode Control.
- Master Controller is turned on.
- Main Circuit Breakers are not tripped.
- Flashhead Fuses F1 and F2 are intact. (Remove power at breakers!)

The charts assume that that you have already eliminated these as possible causes for the observed problem.

The charts may instruct you to make temporary changes for testing (such as select operating modes manually, or installing a jumper). These temporary measures are marked with rectangles with rounded corners. **Always return the systems to their normal state after completing your troubleshooting.** To reduce chart complexity, the charts do not specify the individual actions necessary.

Multiple strobe problems are most commonly cause by faults in the communications cabling. If you have determined that there is a short or break, we recommend disconnecting communication wiring leading to the upper sections of the tower while checking and/or repairing the lower sections. Individual Flashheads may be isolated in the same way. Using this technique, work upward from one Flashhead level to the next, to create known good wiring (per Section 3.5.4).

If the cable test shows an open between TB5-A and TB5-B even though a terminator is set in a top-most strobe, then there is a break in either the A or B line. Use the following test to determine if the break is above or below a Flashhead level.

1. Remove all power from Flashheads and Master Controller at the main circuit breakers.
2. Unplug Data Cable connector TB5 from PCB1 in Master Controller.
3. In one of the Flashheads on a given level, install a jumper (or alligator clip) between TB1-4 and TB1-5.
4. Verify short circuit between (<20 ohms) TB5-A and TB5-B (both on Data Cable). If the measurement is open instead, the break is below that Flashhead level.
5. Remove the jumper between TB1-4 and TB1-5.
6. Plug Data Cable Connector TB5 back into PCB1.

The Troubleshooting charts use the following abbreviations:

- FH Flashhead
- MC Master Controller
- DB Digital Board (inside the SGF-60 Flashhead)
- THVB Trigger/High-Voltage Board (inside the SGF-60 Flashhead)
- RLC Red-Light Controller (such as Honeywell's 9LCA series).

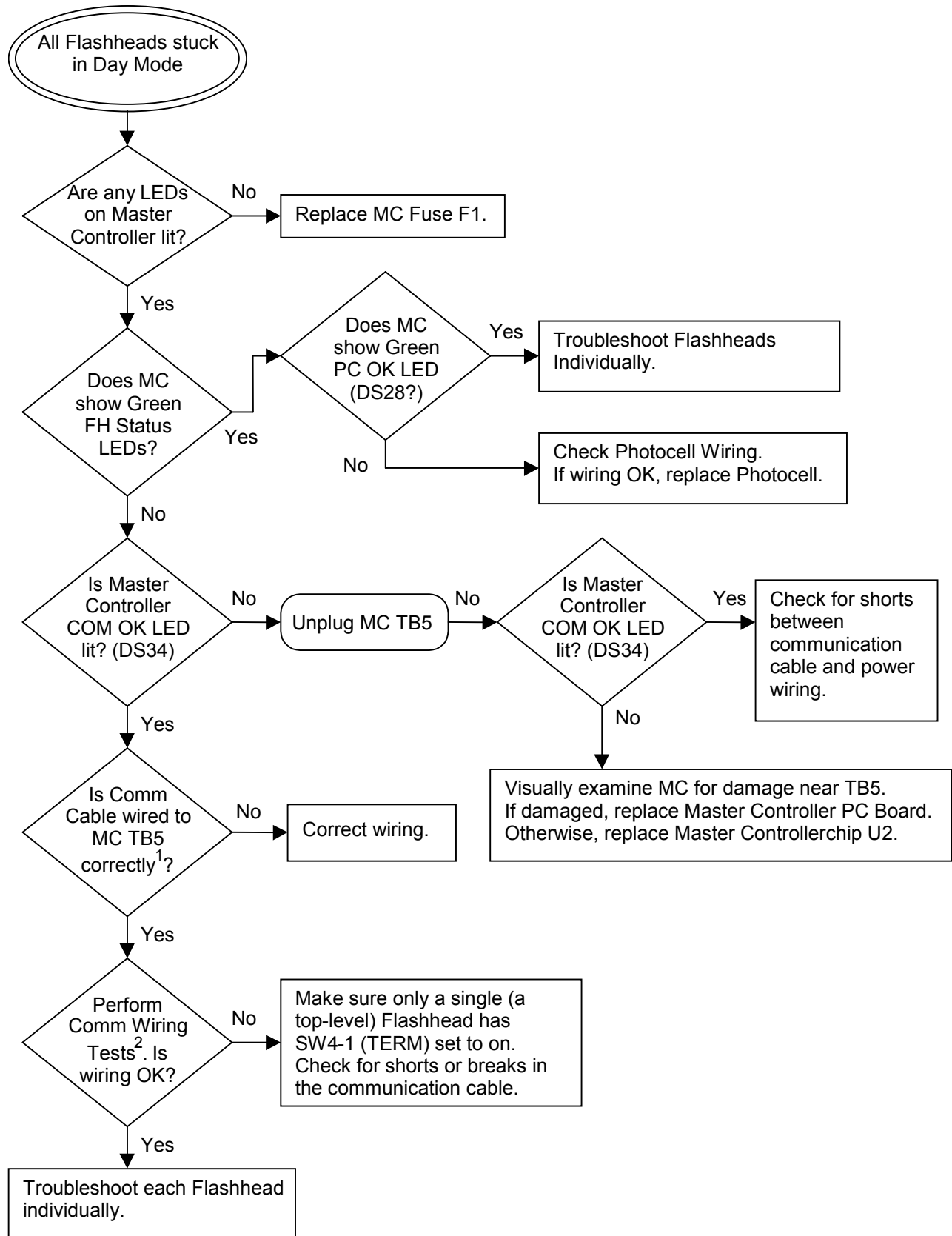

Figure 5-1: General Troubleshooting – All Flashheads Stuck in Day Mode

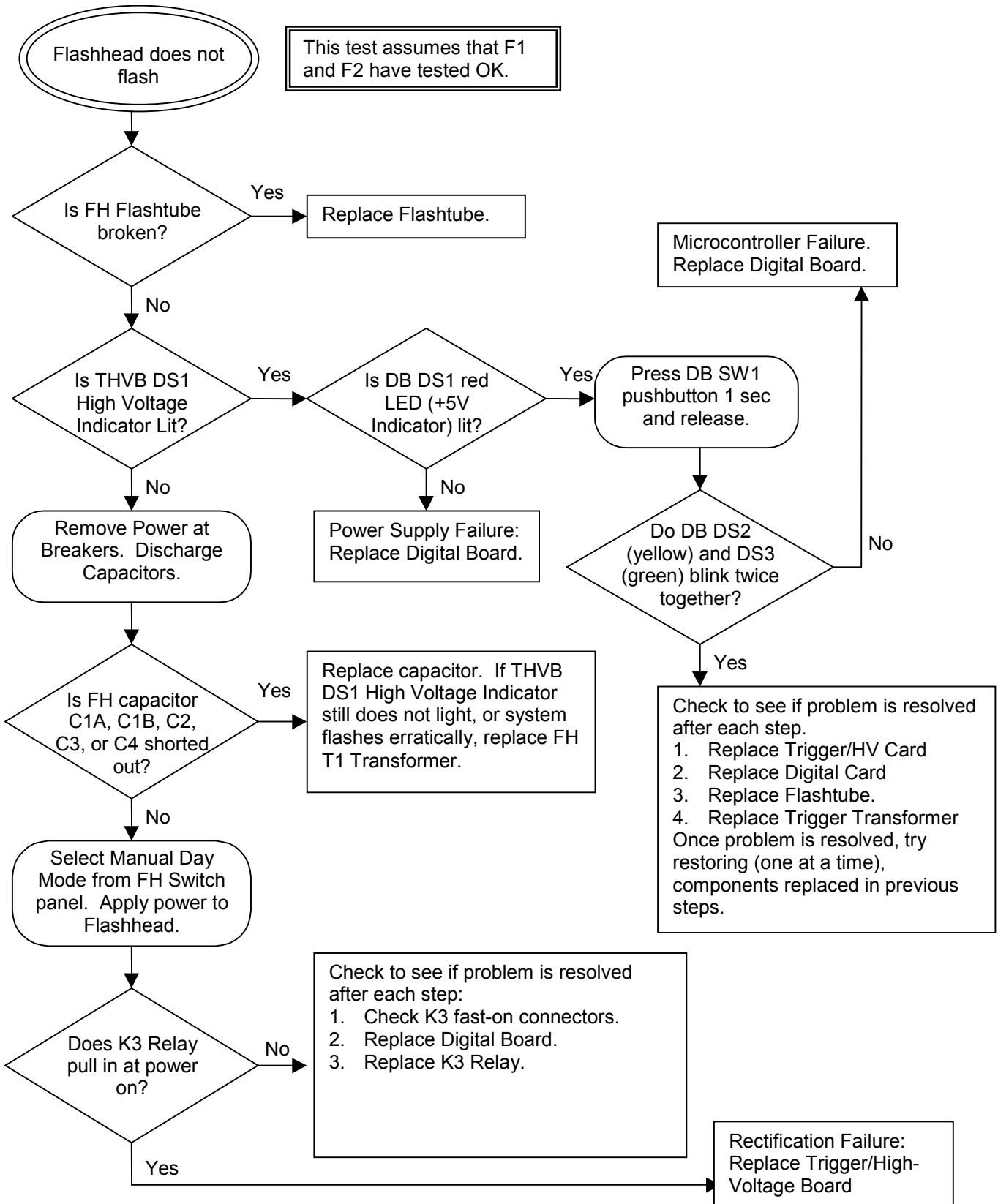

Figure 5-2: General Troubleshooting – Flashhead Does Not Flash

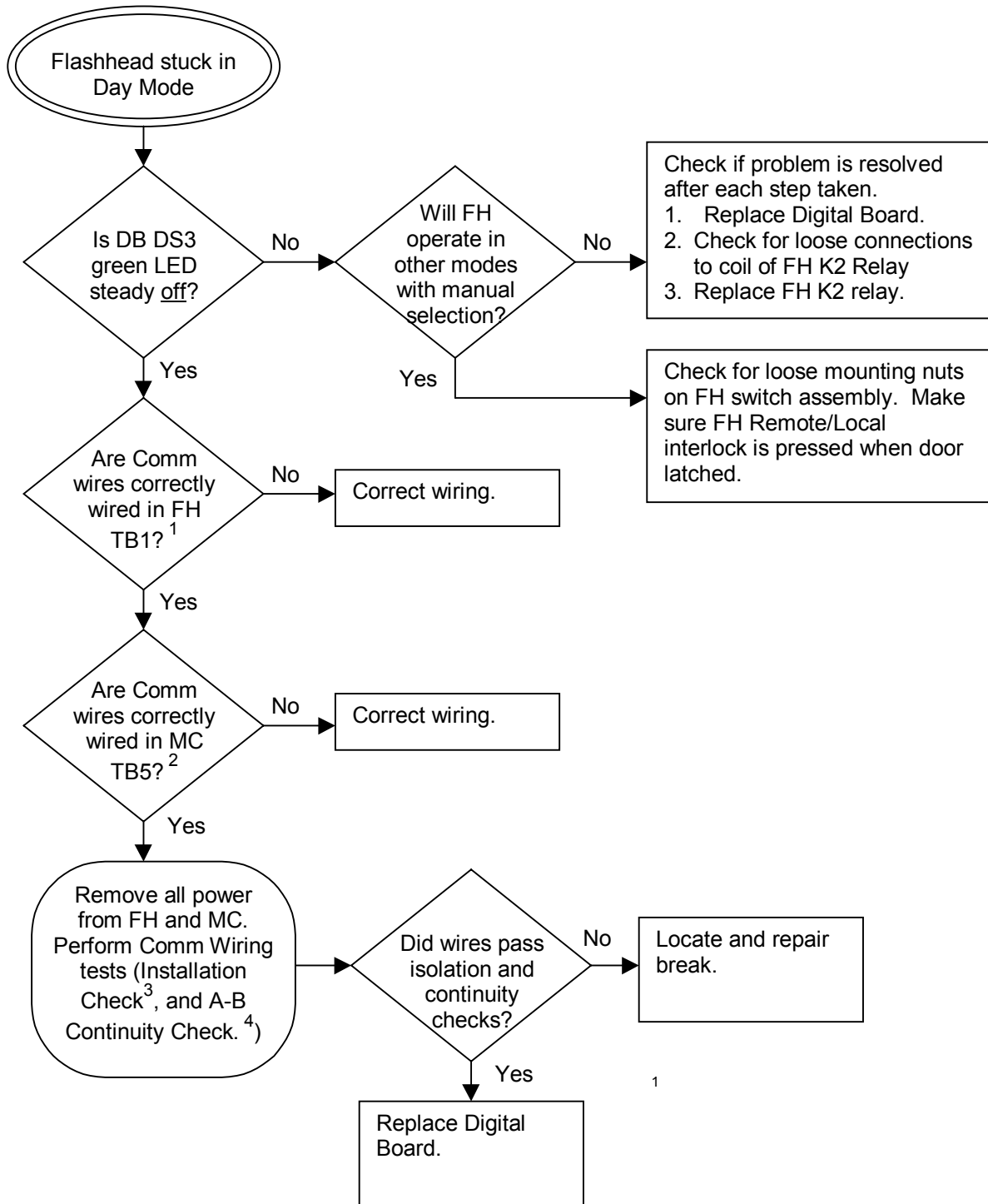
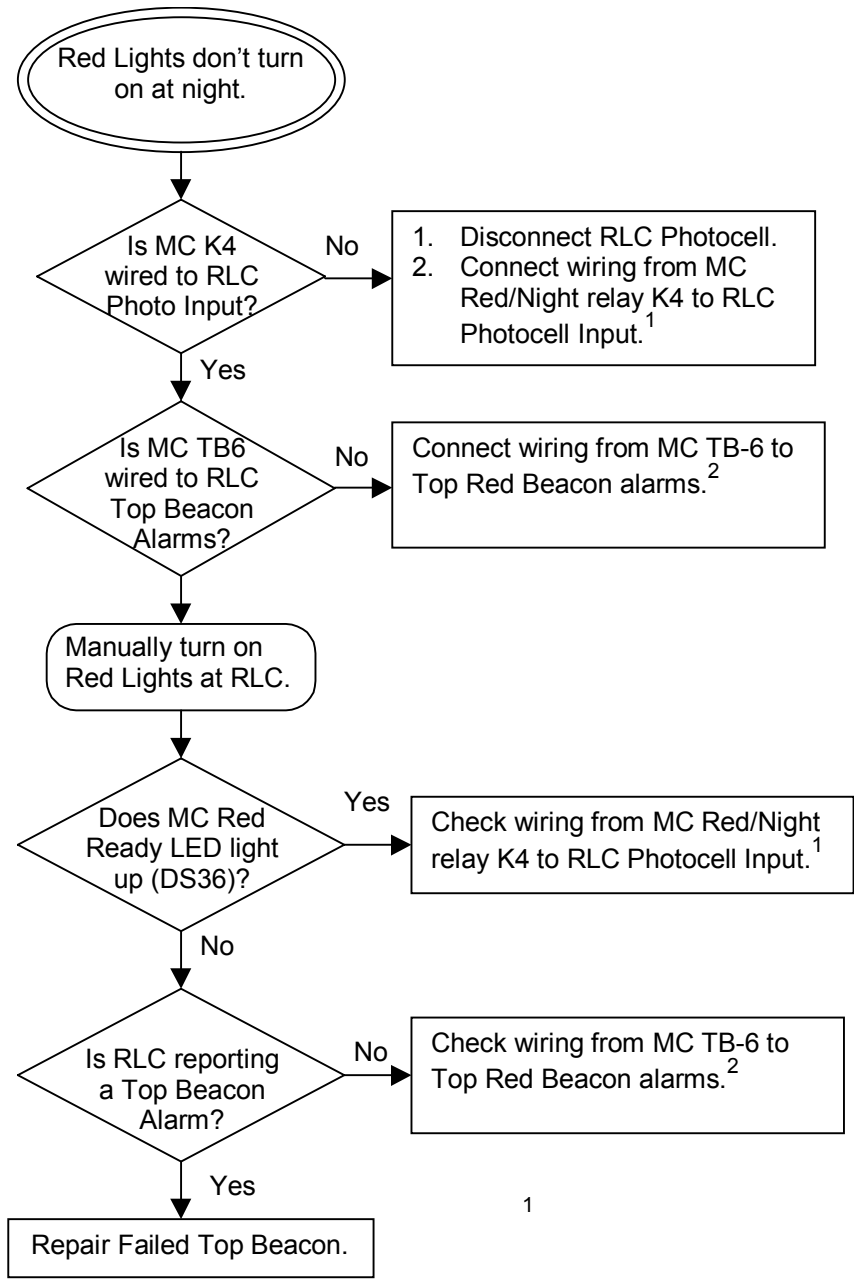

Figure 5-3: General Troubleshooting – Flashhead Stuck in Day Mode





1

Figure 5-4: Dual System-Specific Troubleshooting

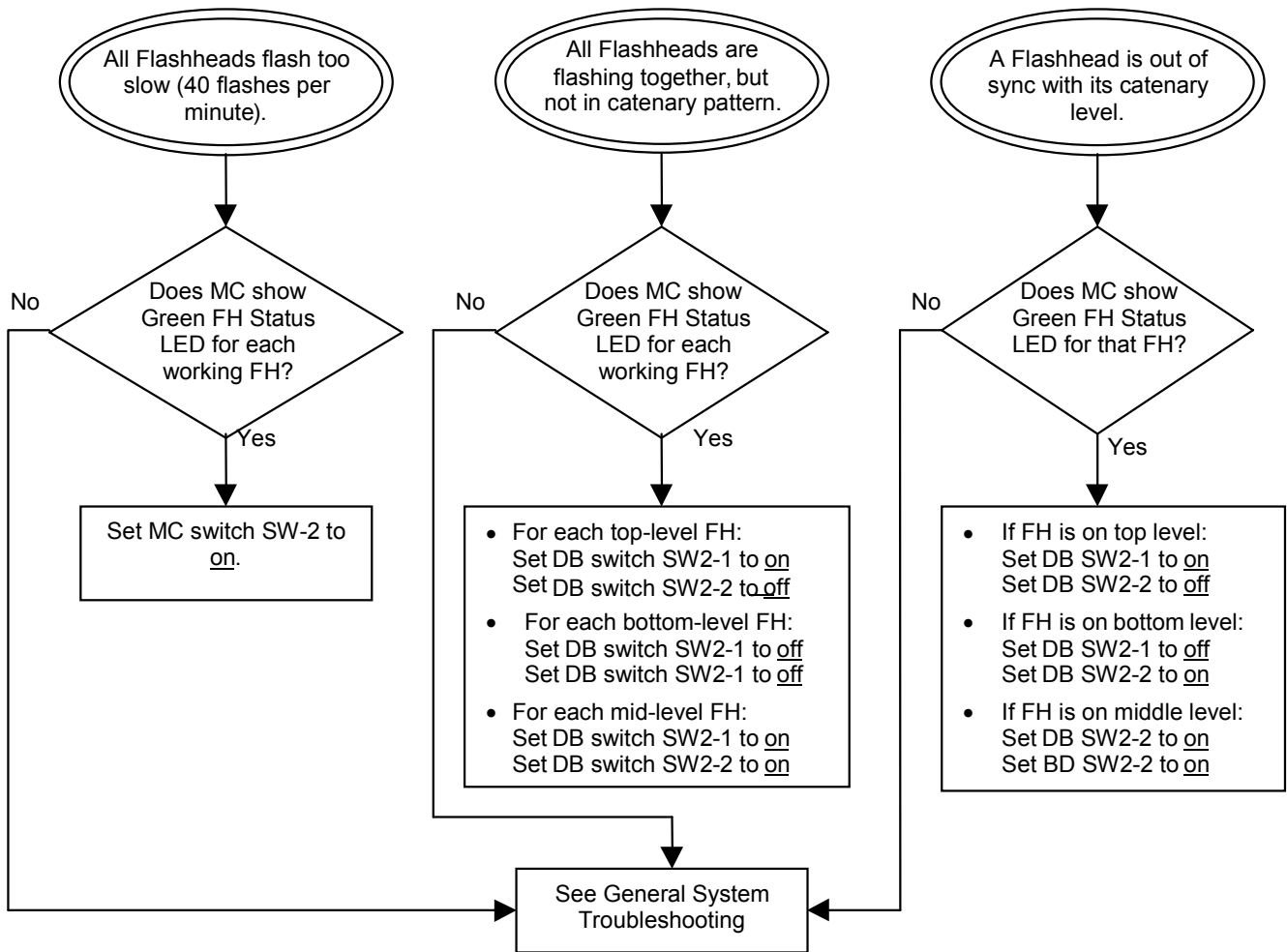

Figure 5-5: Catenary System-Specific Troubleshooting Chart

**SECTION 6. MAINTENANCE**

**6.1 SGC-60 Master Controller**

The Master Controller required no periodic maintenance. However, below are the instructions for installing a new transformer

**6.1.1 Transformer Replacement**

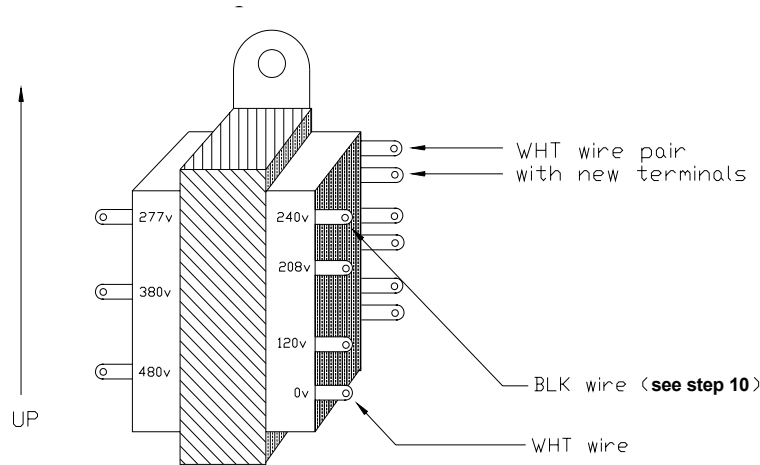

**Figure 6-1: SGC-60 Replacement Transformer**

**Transformer replacement instructions.**

1. Open Controller unit and set power switch to off.
2. Secure Controller input power at the circuit breaker.
3. Verify power to the controller is off.
4. Remove 4 screws attaching Switch panel to standoffs.
5. Swing panel up and out of the way.
6. Remove 2 screws attaching the white wire pair to the transformer outer terminals.
7. Disconnect the black and white wire connectors from transformer inner terminals.
8. Remove 2 screws securing transformer to back panel and remove transformer.
9. Place new transformer in controller with terminals facing right and secure with upper screw only. Bottom screw not matched to back panel but should not affect operation.
10. Attach wires with the push on connectors to the following terminals.
  - (a) **White wire to the outer bottom right terminal**
  - (b) **Black wire to the terminal that matches the Controller input voltage. (240v shown in Figure 6-1.)**
11. You will need to replace the terminal lugs on the other 2 white wires before attaching to the transformer.

- (a) Cut off wire terminal lugs as close to lug as possible
  - (b) Strip insulation back and crimp on new push on connectors.
12. Attach White wires with new connectors to the upper back terminals shown in diagram.
  13. Re-install switch panel assembly to standoffs.
  14. Visually inspect for loose connectors or any short-circuited lines.
  15. Apply power to the Controller from the Circuit breaker.
  16. Set Controller power switch to on and verify normal operation.

## 6.2 SGF-60E Flashhead

Normal maintenance of the Flashhead requires periodic cleaning of the window with a non-abrasive soap.

**WARNING!**

**Ensure that the power is off and the energy storage capacitors have been discharged before opening the Flashhead. Do not put hands or tools in the Flashhead until the High Voltage Indicator neon lamp NE1 on the High Voltage & Trigger board is extinguished. Refer to page 2-3 for the location of High Voltage Indicator NE1 - do not confuse the High Voltage Indicator NE1, with the PWR ON LED.**

**Note that it is possible for the High Voltage Indicator NE1 to be lit even when the PWR ON LED is OFF. If this happens, the energy storage capacitors C1 - C3 must be discharged before performing maintenance.**

### 6.2.1 Flash tube Replacement

Flash tubes that are faulty or degraded in performance by aging shall be replaced per the following procedure:

1. Shut off the power to the system by opening the main AC power circuit breakers.
2. Release the Flashhead cover latches.
3. Swing the cover open, exercising caution not to damage the glass face or the gasket.
4. Release the old flash tube by disconnecting the electrode wire fastons at each end and carefully snapping the flash tube from its holders.
5. Unpack the new flash tube. Do not touch the glass envelope - contamination from a fingerprint will degrade the reliability of the flash tube.
6. Holding the flash tube by its metal ends, center it in the reflector assembly and snap it into place. Make sure the red mark on the flash tube matches the red mark on the socket assembly.

7. Attach the faston connector at each end of the flash tube to each socket assembly. Make sure wires are not twisted - the metal to glass bond is fragile.
8. Refer to Figure 6-2 below. Dress the electrode wires away from the sides of the reflector.
9. Close and fasten the Flashhead cover.

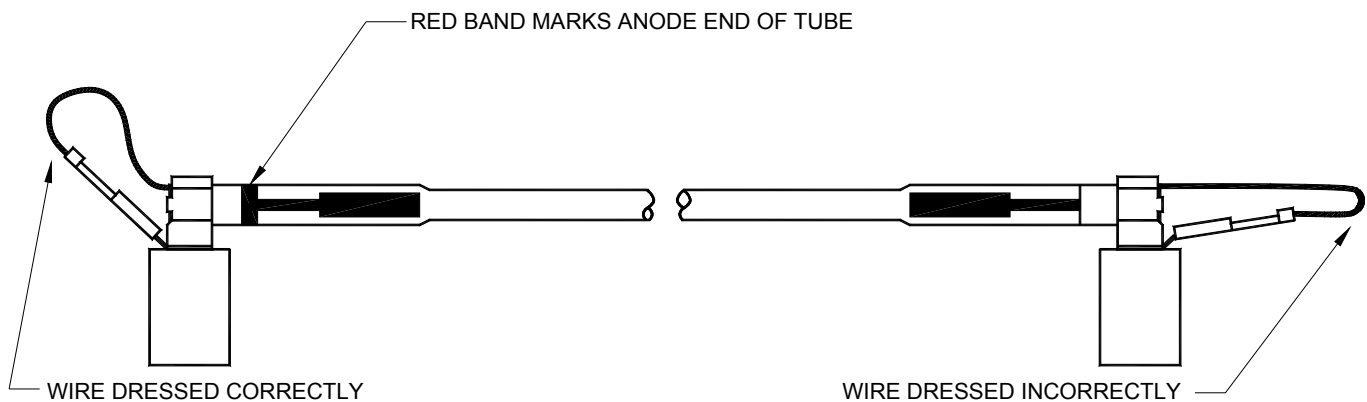

**Figure 6-2: Flash tube Installation**

### 6.3 Ambient Light Sensor (Photocell)

The only maintenance required for the photocell is periodic cleaning. The frequency of cleaning depends on the environment to which the photocell is exposed.

**SECTION 7. REPLACEMENT PARTS**

<u>Description</u>	<u>Part Number</u>
SGF-60E Flashhead	
Capacitor, 1 $\mu$ F, C1-----	86A88105K51
Capacitor, 12.5 $\mu$ F, C2-----	AC000003
Capacitor, 110 $\mu$ F, C3A-----	*77-4133-001
Capacitor, 50 $\mu$ F, C3B-----	AC000002
Flash Tube Assembly, V1-----	40001139-001
Fuse, FNQ, 6A, F1, F2 (for 480VAC)-----	*77-1167
Fuse, FNQ, 10A, F1, F2 (for 208/240VAC)-----	*77-2040
Fuse, FNQ, 12A, F1, F2 (for 120VAC)-----	*77-4136
Wire Harness-----	40001122-001
PC Board, Digital Controller, Programmed-----	40001131-001
PC Board, Trigger-----	40001134-001
PC Board, High Voltage-----	40001128-001
Relays K1, K2, K3-----	*77-3870
Transformer, T1 (60Hz)-----	40001117-001
Transformer, T1 (50Hz)-----	40001141-001
Trigger Transformer-----	*77-3305
Surge Suppressor LA1, LA2 (for 120VAC)-----	2807586
Surge Suppressor LA1, LA2 (for 208,240VAC)-----	2798844
Surge Suppressor LA1, LA2 (for 480VAC)-----	2807609
SGC-60 Master Controller	
PC Board, Master Controller-----	34E00240-001
Transformer, T1 (50Hz / 60Hz)-----	TP000005
Photocell-----	12H00107-001

**SECTION 8. ANTENNA OBSTRUCTION LIGHT (AOL)**

This addendum includes the following Figures:

- Figure 8-1: SG-60 AOL Flashhead Mounting Dimensions
- Figure 8-2: SG-60 AOL Power Supply Mounting Dimensions
- Figure 8-3: SG-60 AOL Wiring Installation
- Figure 8-4: SG-60 AOL Flashhead Component Locations
- Figure 8-5: SG-60 AOL Power Supply Component Location
- Figure 8-6: SG-60 AOL Schematic

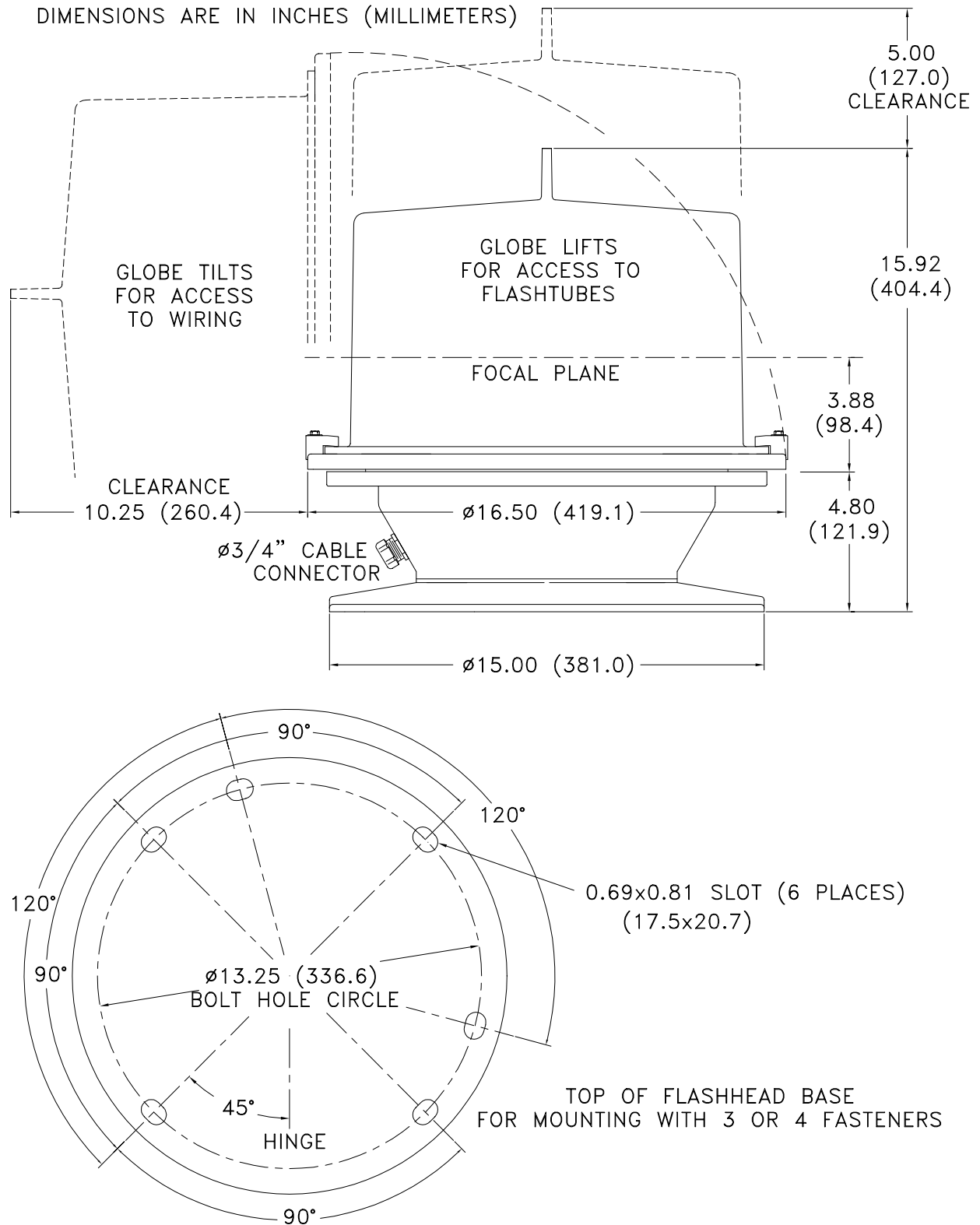

Figure 8-1: SG-60 AOL Flashhead Mounting Dimensions



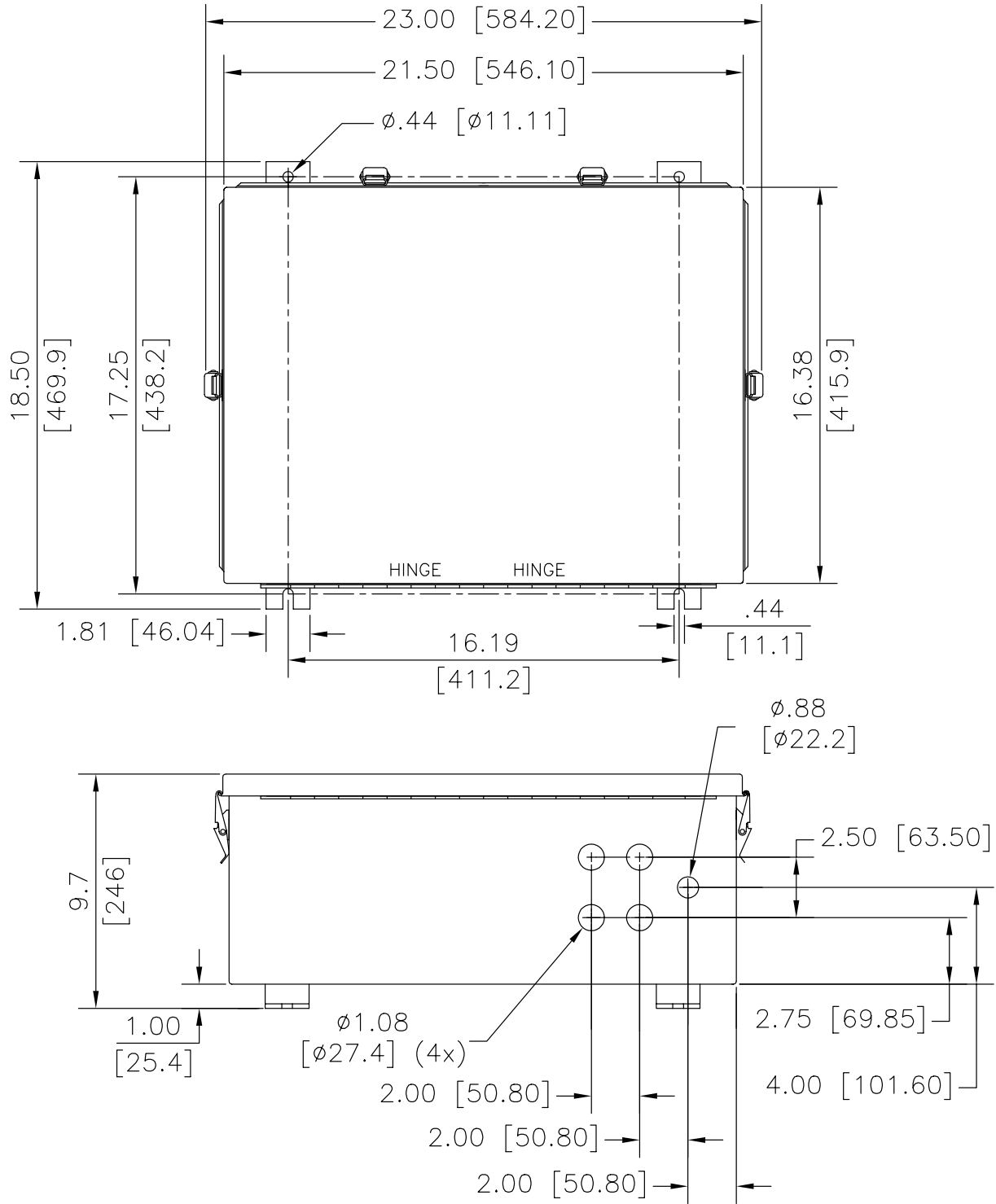

Figure 8-2: SG-60 AOL Power Supply Mounting Dimensions

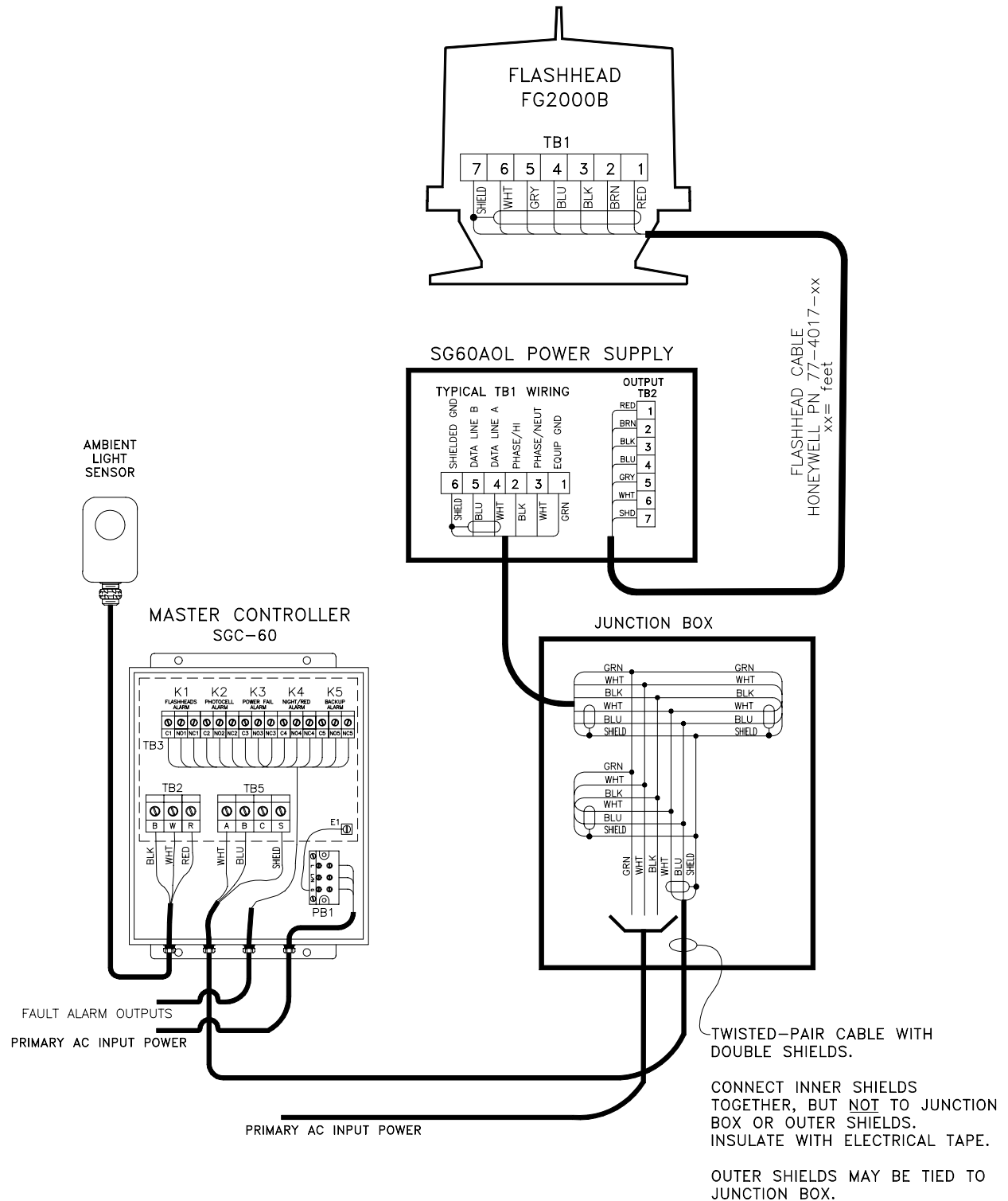

Figure 8-3: SG-60 AOL Wiring Installation

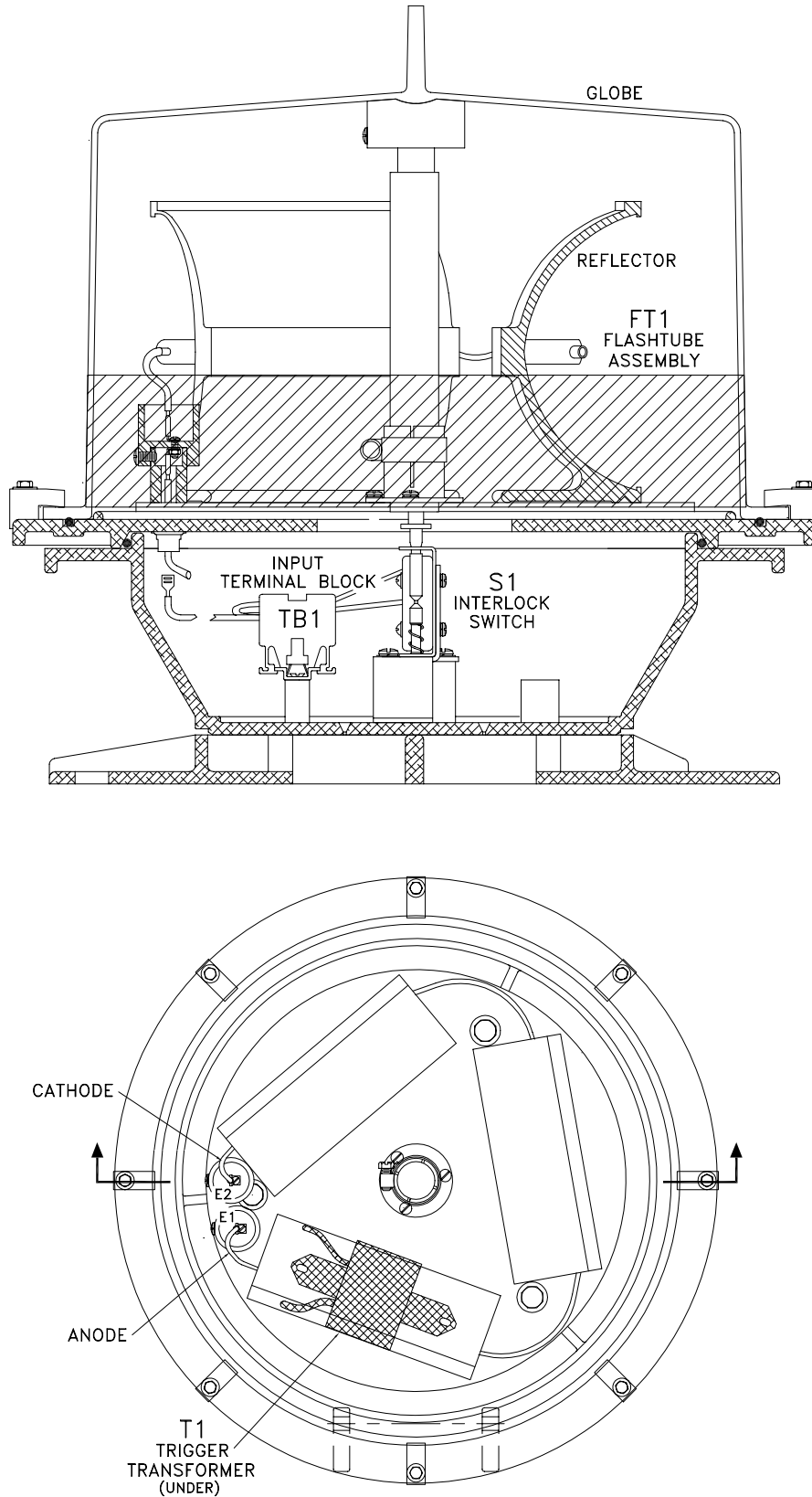
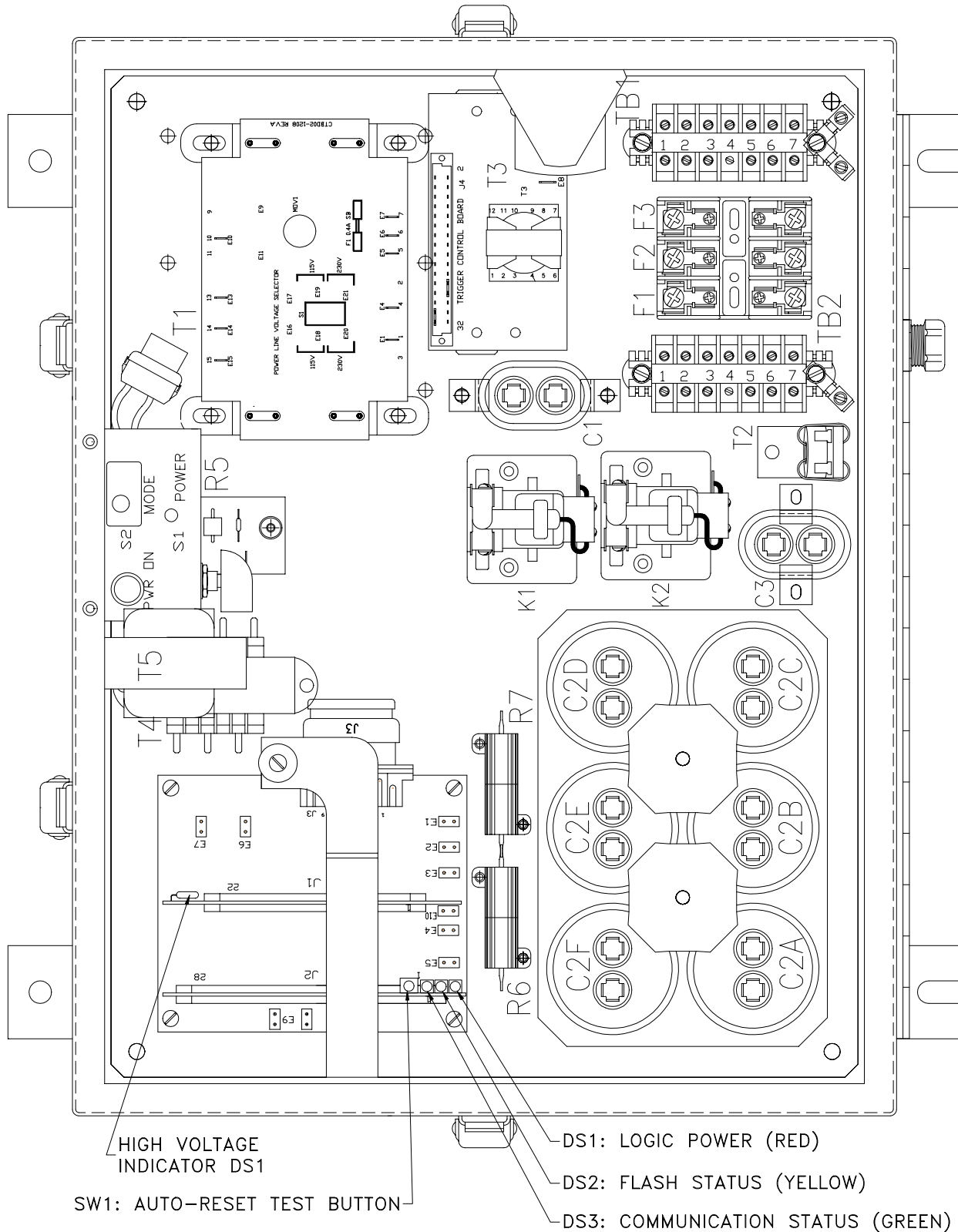

Figure 8-4: SG-60 AOL Flashhead Component Locations



**Figure 8-5: SG-60 AOL Power Supply Component Locations**

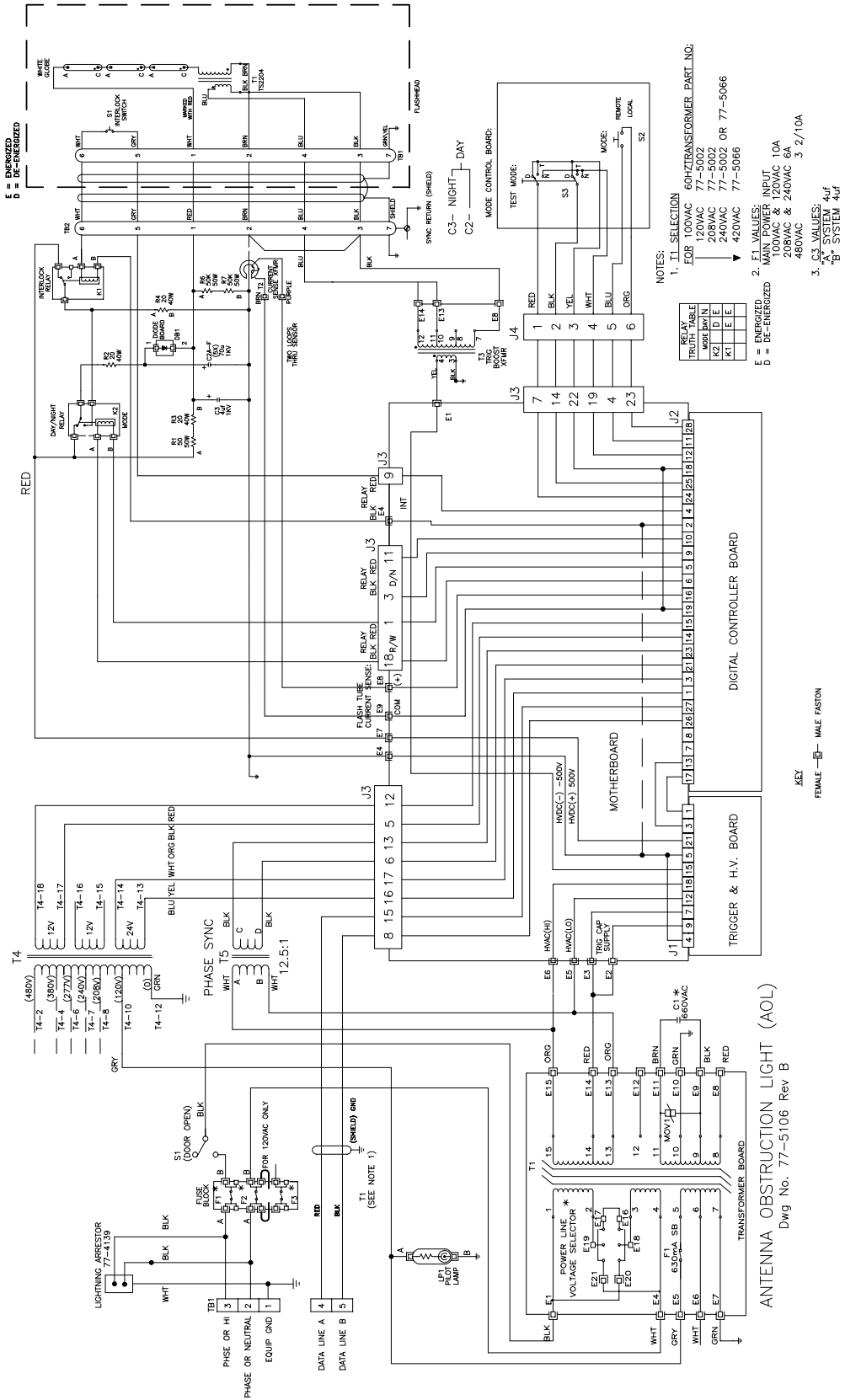

Figure 8-6: SG-60 AOL Schematic